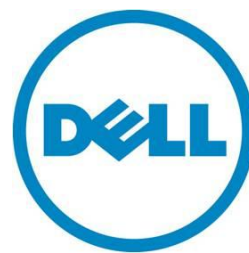

LC Integration Best Practices

A Dell Technical White Paper

Steven Zessin

Ganesh Viswanathan

Zhan Liu



This document is for informational purposes only and may contain typographical errors and technical inaccuracies. The content is provided as is, without express or implied warranties of any kind.

© 2012 Dell Inc. All rights reserved. Dell and its affiliates cannot be responsible for errors or omissions in typography or photography. Dell, the DELL logo, and the DELL badge, PowerConnect, and PowerVault are trademarks of Dell Inc. Microsoft and WinRM are either trademarks or registered trademarks of Microsoft Corporation in the United States and/or other countries. Other trademarks and trade names may be used in this document to refer to either the entities claiming the marks and names or their products. Dell Inc. disclaims any proprietary interest in trademarks and trade names other than its own.

February 2013 | Rev 1.1.0

Contents

1	Contents	12
1.1	How to use this document	12
1.2	Using the sample scripts	12
1.3	Improving winRM enumeration performance	12
1.4	Feature discovery procedure	13
1.5	Profile revision number explanation	14
1.6	LC and LC2 nomenclature	15
1.7	System status and configuration job behavior	15
1.7.1	RS Status and job status.....	16
1.7.2	GetRemoteServicesAPIStatus and job status	17
1.7.3	11G and 12G compatibility.....	18
1.7.4	GetRemoteServicesAPIStatus output descriptions	19
1.8	Reference links.....	20
2	Terms and Definitions	21
3	Anomalous Algorithms and Descriptions	22
3.1	Setting CNA bandwidth	22
3.2	iDRAC cloning.....	22
3.3	Setting NIC string attributes to blank.....	23
3.4	Determine NIC card	23
3.5	List of partitionable NIC cards for LC2.....	24
3.6	iDRAC Telnet attribute enables SerialRedirection.....	24
3.7	Never unplug hardware during updates	25
3.8	Express versus Enterprise iDRACs.....	25
3.9	CIM Query Language (CQL) Filters	26
3.9.1	CQL filter benefits.....	26
3.9.2	How to perform CQL enumerations using RECITE.....	26
3.9.3	CQL filter example that enumerates all NIC attributes for a particular port/partition	26
3.9.4	CQL filter example that enumerates all iDRAC attributes with a particular GroupDisplayName and AttributeName	27
3.9.5	CQL filter example that enumerates all BIOS attributes where the IsReadOnly flag is set to TRUE	27
3.10	Ordering of iDRAC attributes to set or apply (11G vs 12G)	27
3.11	How to determine if server is 11G or 12G.....	28
3.12	Using special characters in usernames.....	28
3.13	Obtaining Updated System Inventory	28

3.14	How to determine if the system is blade, tower, or rack	30
3.15	Getting the SystemID, Model, and more.....	30
3.16	Http, CIFS, NFS, tftp, ftp formatting	31
4	Workflows	32
4.1	RAID stacking: ResetConfig, CreateVD, assign HotSpares	32
4.2	RAID stacking with BIOS attributes using Setupjobqueue	33
4.3	Boot to network ISO	35
4.4	Boot to ISO from vFlash	36
4.5	Set hard drive to first in boot order.....	37
4.6	Export (backup) image to vFlash.....	38
4.7	Export (backup) image to CIFS or NFS share.....	38
4.8	Import (restore) image from vFlash	39
4.9	Import (restore) image from CIFS or NFS share	39
4.10	iDRAC firmware DUP update from CIFS or TFTP share	40
4.11	BIOS firmware DUP update from CIFS or TFTP share	41
4.12	USC firmware DUP update from CIFS or TFTP share.....	42
4.13	PXE Boot using embedded NICs (11G only).....	43
4.14	PXE Boot using embedded NICs (12G only).....	45
4.15	Set NIC attributes and iSCSI boot using setupjobqueue (11G only).....	46
4.16	iSCSI boot using NDC/Broadcom (12G only).....	48
4.17	iSCSI boot using QLogic (12G only)	49
4.18	iSCSI boot using Intel (12G only)	51
4.19	IO Identity	53
4.20	Export LC log	54
4.21	FCoE boot using QLogic (12G only)	54
4.22	FCoE boot using Intel (12G only).....	56
4.23	FCoE boot using Broadcom (12G only)	59
4.24	IO Identity for QLogic (12G only)	61
4.25	IO Identity for Broadcom (12G only)	62
4.26	IO Identity for Intel (12G only).....	64
4.27	Export System Configuration (12G only).....	65
4.28	Import System Configuration (12G only)	65
4.29	Configurable Boot to network ISO	66
5	Base Metrics Profile Use Cases	67
5.1	Discovery of Base Metrics profile support.....	67

6	BIOS and Boot Management Profile Use Cases	68
6.1	Discovery of BIOS and boot profile support	68
6.2	List all BIOS attributes	69
6.3	Delete pending BIOS configuration	69
6.4	Inventory of boot configurations in system	70
6.5	Get the first boot configuration's information	70
6.6	Inventory of boot sources in system.....	71
6.7	Changing boot order by instance	71
6.8	Enable or disable boot source	71
6.9	One time boot	72
7	CPU Profile Use Cases	73
7.1	Discovery of CPU profile support	73
7.2	Inventory of CPUs in system	73
7.3	Get the first CPU's information	74
8	Event Filter Profile Use Cases	74
8.1	Discovery of Event Filter profile support	74
8.2	Get event filter configuration service views	75
8.3	Get event filter views	75
8.4	Get single event filter's information.....	76
8.5	Set event filters by category	76
8.6	Set event filters by InstanceID	76
9	iDRAC Card Profile Use Cases	77
9.1	Discovery of iDRAC Card profile support	77
9.2	Get all iDRAC card attributes.....	78
9.3	Inventory of iDRAC cards in system	78
9.4	Get the first iDRAC card's information	79
9.5	Set/apply iDRAC card attribute(s) immediately	79
9.6	Schedule a set iDRAC card attribute(s) operation	80
10	Fan Profile Use Cases	80
10.1	Discovery of Fan profile support	80
10.2	Inventory of fans in system	81
10.3	Get the first fan's information	81
11	Persistent Storage Profile Use Cases	82
11.1	Discovery of Persistent Storage profile support.....	82
11.2	Inventory of virtual flash (vFlash) media	82

11.3	Get the first vFlash's attribute information	83
11.4	Inventory of partitions on the virtual flash media.....	83
11.5	Initialize virtual flash media.....	83
11.6	Enable virtual flash (vFlash) media.....	84
11.7	Disable virtual flash (vFlash) media	84
11.8	Create new partition on virtual flash (vFlash) media	85
11.9	Create new partition using image	85
11.10	Delete existing partition	86
11.11	Format existing partition.....	86
11.12	Modify existing partition	87
11.13	Attach partition	87
11.14	Detach partition	87
11.15	Export data from existing partition	88
12	Power State Management Profile Use Cases	88
12.1	Discovery of Power State Management profile support.....	88
13	Profile Registration Profile Use Cases	89
13.1	Discovery of Profile Registration profile support	89
14	Simple RAID Profile Use Cases.....	90
14.1	Discovery of RAID profile support.....	90
14.2	Inventory of RAID controllers in system	91
14.3	Get the first RAID controller's information	91
14.4	Inventory of virtual and physical disks in system	92
14.5	Apply pending values for a RAID configuration.....	92
14.6	Delete pending values for a RAID configuration.....	92
14.7	Clear old configuration from newly added hard drive	93
14.8	Determine available RAID configurations	93
14.9	Determine available physical disks for a RAID configuration	94
14.10	Check available virtual disk parameters for a given RAID level and set of physical disks ..	94
14.11	Create a virtual disk	95
14.12	Determine available physical disks to be used as a hotspare.....	95
14.13	Assign a physical disk as a hotspare	95
14.14	Delete a virtual disk from the system	95
14.15	Delete all virtual disks and unassign all hotspares	96
14.16	Convert physical disks to RAID state	96
14.17	Convert physical disks to non-RAID state.....	97

15	Record Log Profile Use Cases	98
15.1	Discovery of Record Log profile support.....	98
15.2	List Lifecycle record logs.....	99
15.3	List Lifecycle record log capabilities.....	99
15.4	List Lifecycle log entries	100
15.5	Set and get comment in Lifecycle log entries	100
15.6	List system event record logs	101
15.7	List system event record log capabilities	101
15.8	List system event log entries	101
16	Role Based Authorization Profile (RBAP) use cases	102
16.1	Discovery of RBAP profile support	102
16.2	Discovery of users with assigned LAN privileges	103
16.3	Discovery of users with assigned serial over LAN privileges	103
16.4	Discovery of users with assigned CLP privileges	103
17	Service Processor Profile Use Cases	104
17.1	Discovery of Service Processor profile support	104
18	Simple NIC Profile Use Cases	105
18.1	Discovery of Simple NIC profile support	105
18.2	Inventory of NICs in system	105
18.3	Get the first NIC's information.....	106
18.4	List all NIC attributes	106
18.5	Delete pending NIC values	106
18.6	Discovery of NIC capabilities	107
19	Software Update Profile use cases	108
19.1	Discovery of Software Update profile support	108
20	Job Control Profile Use Cases	109
20.1	Discovery of Job Control profile support	109
20.2	List all jobs in job store	109
20.3	Get one job's information	110
20.4	Delete all jobs from job store (job queue) using "JID_CLEARALL"	110
20.5	Delete one job from job store	111
21	Memory Profile Use Cases	111
21.1	Discovery of Memory profile support.....	111
21.2	Inventory of memory in system	112
21.3	Get the first memory's information.....	112

22	PCI Device Profile Use Cases	113
22.1	Discovery of PCI Device profile support	113
23	Sensors Profile Use Cases	114
23.1	Discovery of Sensor profile support	114
23.2	Inventory of sensor in system	114
23.3	Sensor thresholds	115
24	Base Server and Physical Asset Profile Use Cases.....	115
24.1	Discovery of Base Server and Physical Asset profile support	115
24.2	Discovery of Base Server and Physical Asset profile support [LC1.5.1]	116
24.3	List all CIM profiles.....	117
25	Video Profile Use Cases.....	118
25.1	Discovery of Video profile support	118
25.2	Inventory of video in system.....	119
25.3	Get the first video instance's information	119
26	License Management Profile Use Cases.....	119
26.1	Discovery of License Management profile support	119
27	Power Supply Profile Use Cases.....	120
27.1	Discovery of Power Supply profile support.....	120
27.2	Inventory of power supplies in system.....	121
27.3	Get the first power supply's information	122
27.4	Get MAC information.....	122
27.5	Get blade power	122
28	System Info Profile Use Cases	123
28.1	Discovery of System Info profile support	123
28.2	Inventory of system info view	124
28.3	Get the first system info view's information	124
28.4	Inventory of all system attributes in system.....	125
28.5	Get a single system string attribute.....	125
28.6	Setting and applying system attributes.....	125
28.7	Apply pending system attribute values	126
28.8	Delete pending system attribute values.....	126
29	Software Inventory Profile Use Cases	127
29.1	Instance diagram	127
29.2	Discovery of Software Inventory profile support.....	128
29.3	Inventory of software in system	129

29.4	Get the installed BIOS firmware inventory.....	129
29.5	Get the available iDRAC firmware inventory	130
30	Simple Identity Management Profile Use Cases	130
30.1	Discovery of Simple Identity Management profile support	130
31	LC Management Profile Use Cases	131
31.1	Discovery of LC Management profile support.....	131
31.2	Inventory of LC Management attributes in system	132
31.3	Check and enable (or disable) Collect System Inventory on Restart (CSIOR)	133
31.4	Check version of Lifecycle Controller (LC).....	133
31.5	Get “Part Firmware Update” attribute	134
31.6	Check vFlash license enablement	134
31.7	Set configuration to “Auto Discovery Factory Defaults”	135
31.8	Clear provisioning server	136
31.9	Replace auto discovery public key	136
31.10	Replace auto discovery client certificate, private key and password.....	136
31.11	Delete auto discovery public key	136
31.12	Delete auto discovery client certificat, private key and password.....	137
31.13	Replace iDRAC web server client certificate and private key	137
31.14	Replace iDRAC web server public certificate.....	137
31.15	Insert comment into Lifecycle log.....	137
31.16	Export and view the content of the Lifecycle log	137
31.17	Export and view the current hardware inventory.....	137
31.18	Export and view the hardware inventory as shipped from the factory	138
32	OS Deployment Profile Use Cases.....	138
32.1	Discovery of OS Deployment profile support	138
32.2	Unpack and attach drivers	139
32.3	Connect and attach network ISO image	139
32.4	Disconnect and detach network ISO image	139
32.5	Get ISO image connection status	140
32.6	One time ISO boot skip	140
32.7	Remote File Share (RFS) use cases	140
32.7.1	Connect and Attach Network ISO Image as a USB CD-ROM device via RFS USB end point. 140	
32.7.2	Disconnect and detach ISO Image exposed via RFS USB end point	141
32.7.3	Get RF ISO Image connection Status	141

32.8	Boot to hard drive (HD).....	141
33	Appendix	143
33.1	PYTHON scripts README.....	143
33.1.1	Purpose.....	143
33.1.2	Requirements	143
33.1.3	Command line.....	143
33.1.4	Commands	144
33.1.5	Settable variables	146
33.1.6	Internal variables.....	147
33.2	System check information	148
33.2.1	Check System Power State.....	148
33.2.2	Check RS status	148
33.2.3	Check for pending jobs	148
33.2.4	Check for pending configuration.....	148
33.2.5	Check CSIOR state	148
33.3	Inventory information.....	148
33.3.1	System inventory	148
33.3.2	Software inventory	149
33.3.3	BIOS inventory	149
33.3.4	Boot order inventory.....	149
33.3.5	NIC inventory.....	149
33.3.6	RAID inventory	149
33.4	Poll LC jobs information.....	149
33.4.1	Timing considerations	149
33.4.2	Machine reboot	149
33.4.3	POST	150
33.4.4	SSM.....	150
33.4.5	RSSStatus/JobStatus	151
33.4.6	Check refreshed data	151
33.4.7	CSIOR	151
33.5	iSCSI boot information	151

Tables

Table 1.	Generational Nomenclature.....	15
----------	--------------------------------	----

Figures

Figure 1. Typical Life Cycle of an 11G (LC1.5.0 & LC1.5.1) Configuration Job 16

Figure 2. Typical Life Cycle of a 12G Configuration Job 17

Figure 3. Compatibility with 11G Workflows 18

Figure 4. Software Inventory: Instance Diagram 127

1 Contents

1.1 How to use this document

This document contains the detailed steps of common workflows to perform various tasks utilizing winRM or WSMAN. The PYTHON scripting language was used to provide a software development kit (SDK) for Lifecycle Controller (LC) API methods. Two primary objectives are addressed: first, that workflows documentation provides guidance to established, known, working API methodologies, and second, that corresponding PYTHON sample scripts are separately provided. After invoking these scripts, the output log can be used to provide approximate timing on a particular system configuration, as well as raw winRM or WSMAN input and output.

1.2 Using the sample scripts

Refer to the appendix for a full text README.

Getting started:

- 1) Install Python 2.4 to 2.6
- 2) Download scripts folder to desired location; no installation necessary

Running a script:

- 1) cd to scripts directory
- 2) python recite.py (opens command prompt of application)
- 3) set \$IP 12.34.56 (Enter actual IP)
- 4) log whateverfilename.log w (may use any name for filename)
- 5) batch bestpracticeflows\script_name.win (launches script)

Note: A .win file is simply a text file containing calls to the recite PYTHON script.

Other commands:

-help (lists all available commands)

-set (list current IP, username, password, etc.)

Notes:

File output will be placed in scripts directory

1.3 Improving winRM enumeration performance

When an enumeration command is executed, the default WinRM configuration gets only 20 instances at a time and therefore slows down the system drastically. Changing the WinRM configuration to allow a greater number, such as 50, will reduce the time taken by the enumeration operations.

Also see section 3.9 for using CQL filters on enumerations.

Execute the following command to get instances in groups of up to 50.

```
winrm set winrm/config @{MaxBatchItems="50"}
```

Additionally, increasing the allotted maximum envelope size and timeout can also increase performance.

```
winrm set winrm/config @{MaxEnvelopeSizekb="150"}
```

```
winrm set winrm/config @{MaxTimeoutms="60000"}
```

Other optional WinRM configuration commands are listed below for convenience. To get the current WinRM configuration settings, execute the following command.

```
winrm g winrm/config
```

By default, the client computer requires encrypted network traffic. To allow the client computer to request unencrypted traffic, execute the following command:

```
winrm s winrm/config/Client @{AllowUnencrypted="true"}
```

TrustedHosts is an array that specifies the list of remote computers that are trusted. Other computers in a workgroup or computers in a different domain should be added to this list.

Note: The computers in the *TrustedHosts* list are not authenticated.

Execute the following command to allow all computers to be included in *TrustedHosts*.

```
winrm s winrm/config/Client @{TrustedHosts="*"}
```

Basic authentication is a scheme in which the user name and password are sent in clear text to the server or proxy. This method is the least secure method of authentication. The default is True.

Execute the following command to set client computer to use Basic authentication.

```
winrm s winrm/config/Client/Auth @{Basic="true"}
```

1.4 Feature discovery procedure

There are four steps recommended to determining the feature set on a given system.

- 1) Interop namespace - registered profile advertisement
 - a. winrm enumerate "cimv2/CIM_RegisteredProfile?__cimnamespace=root/interop" -r:https://IPADDRESS/wsman -u:username -p:password -SkipCNcheck -SkipCAcheck -encoding:utf-8 -a:basic -format:pretty
 - b. The output from above will provide the *RegisteredVersion* of each supported profile on the system. The *RegisteredVersion* field can be used to determine the profile's feature set. See Section 1.4 for more information.
- 2) Capability properties on views (NIC example)
 - a. winrm enumerate "cimv2/root/dcim/DCIM_NICCapabilities" -r:https://IPADDRESS/wsman -u:username -p:password -SkipCNcheck -SkipCAcheck -encoding:utf-8 -a:basic -format:pretty
 - b. The output from above will provide the available properties of each view.
- 3) Capability Attributes (RAID example)

- a. Enumerate the `DCIM_RAIDString`, `DCIM_RAIDEnumeration`, and `DCIM_RAIDInteger` classes (`DCIM_RAIDString` shown below)

```
winrm enumerate "cimv2/root/dcim/DCIM_RAIDString" -r:https://IPADDRESS/wsman=-u:username -p:password -SkipCNcheck -SkipCAcheck -encoding:(utf)-8 -a:basic -format:pretty
```

- b. The output from above will provide the available attributes of each class

4) Firmware versioning

- a. `winrm enumerate "cimv2/root/dcim/DCIM_SoftwareIdentity" -r:https://IPADDRESS/wsman -u:username -p:password -SkipCNcheck -SkipCAcheck -encoding:utf-8 -a:basic -format:pretty`

- b. The output from above will list all available and installed firmwares and corresponding firmware versions. Examining the version of these firmwares, such as Lifecycle controller and iDRAC, can be used to determine the feature set

1.5 Profile revision number explanation

Profile revision numbers are a key metric in determining the available feature set. Examples of discovering, or obtaining, profiles are covered extensively in this document along with example output.

The example shown below is for the LC Management profile. Discovering a particular profile on a system is a three step process.

- 1) Enumerate the `DCIM_LCRegisteredProfile` class to view all available profiles
- 2) Search the `RegisteredName` field for the desired profile
- 3) Search for the `RegisteredVersion` field, which is the characteristic used to identify the supported features.

```
DCIM_LCRegisteredProfile  
AdvertiseTypeDescriptions = WS-Identify  
AdvertiseTypeDescriptions = Interop Namespace  
AdvertiseTypes = 1  
AdvertiseTypes = 1  
InstanceID = DCIM:LCManagement:1.1.0  
OtherRegisteredOrganization = DCIM  
ProfileRequireLicense = Auto Discovery  
ProfileRequireLicense = Part Replacement  
ProfileRequireLicense = Remote Firmware Configuration  
ProfileRequireLicense = Remote Inventory Export  
ProfileRequireLicense = Server Profile Export and Import  
ProfileRequireLicenseStatus = LICENSED  
ProfileRequireLicenseStatus = LICENSED  
ProfileRequireLicenseStatus = LICENSED  
ProfileRequireLicenseStatus = LICENSED  
ProfileRequireLicenseStatus = LICENSED  
RegisteredName = LC Management  
RegisteredOrganization = 1  
RegisteredVersion = 1.4.0
```

The `RegisteredVersion` field is in the following format:

[major change] . [minor change] . [errata]

- Increments in the major change field indicate that the profile is not backward compatible.
- Increments in the minor change field indicate that one or more new methods have been added.
- Increments in the errata field indicate that one more defects have been fixed.

1.6 LC and LC2 nomenclature

This section describes the new terminology associated with the new generation of hardware and Lifecycle Controller firmware (including iDRAC). The new hardware platform is generically referred to as 12G and all corresponding Lifecycle Controller firmware will be LC2 with accompanying sub releases (i.e. 1.0.0, 1.1.0, etc.). The table below summarizes both the past and current generational nomenclature.

NOTE: Data within table is for illustration purposes only.

Table 1. Generational Nomenclature

Hardware	Lifecycle Controller Firmware
11G	LC 1.5.0
11G	LC 1.5.1
11G	LC 1.5.2
11G	LC 1.x.x
12G	LC2 1.0.0
12G	LC2 1.0.1
12G	LC2 1.1.0
12G	LC2 1.1.1
12G	LC2 1.x.x

Changes in the Lifecycle Controller firmware versions abide by the following definition:

[major change] . [minor change] . [errata]

- Increments in the major change field indicate that the profile is not backward compatible.
- Increments in the minor change field indicate that one or more new methods have been added.
- Increments in the errata field indicate that one more defects have been fixed.

1.7 System status and configuration job behavior

The details below describe the generational evolution of how a typical configuration job relates to the state of the system.

1.7.1 RS Status and job status

The details below describe how the remote service (RS) status relates to the job status. RS status is a feature that indicates whether the system is ready to invoke WSMAN commands. It must be in a *ready* state before executing any WSMAN commands.

NOTE: The RS Status method was introduced in LC1.5.0.

Figure 1. Typical Life Cycle of an 11G (LC1.5.0 & LC1.5.1) Configuration Job

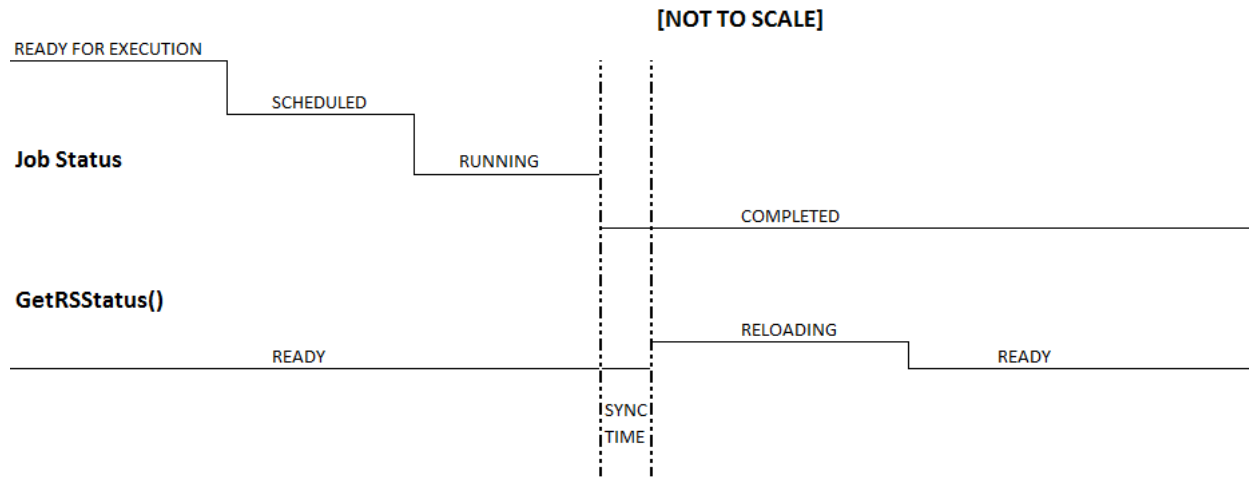

After the job is complete in Automated Task Application (previously SSM), the job status is immediately updated in the job store. The job is moved immediately to the *Completed* state once it is complete in the Automated Task Application. As seen in the timeline diagram above, after the job is *Completed*, the sync happens in the configDB, and then the RS status goes to *Reloading* state. After all the required populators are refreshed successfully, the RS status goes to *Ready* state. The user/console can see the new values only when the RS status goes to the *Ready* state.

1.7.2 GetRemoteServicesAPIStatus and job status

The introduction of the new GetRemoteServicesAPIStatus method alleviates the ambiguity of the GetRSStatus method regarding when the system is *ready*.

Figure 2. Typical Life Cycle of a 12G Configuration Job

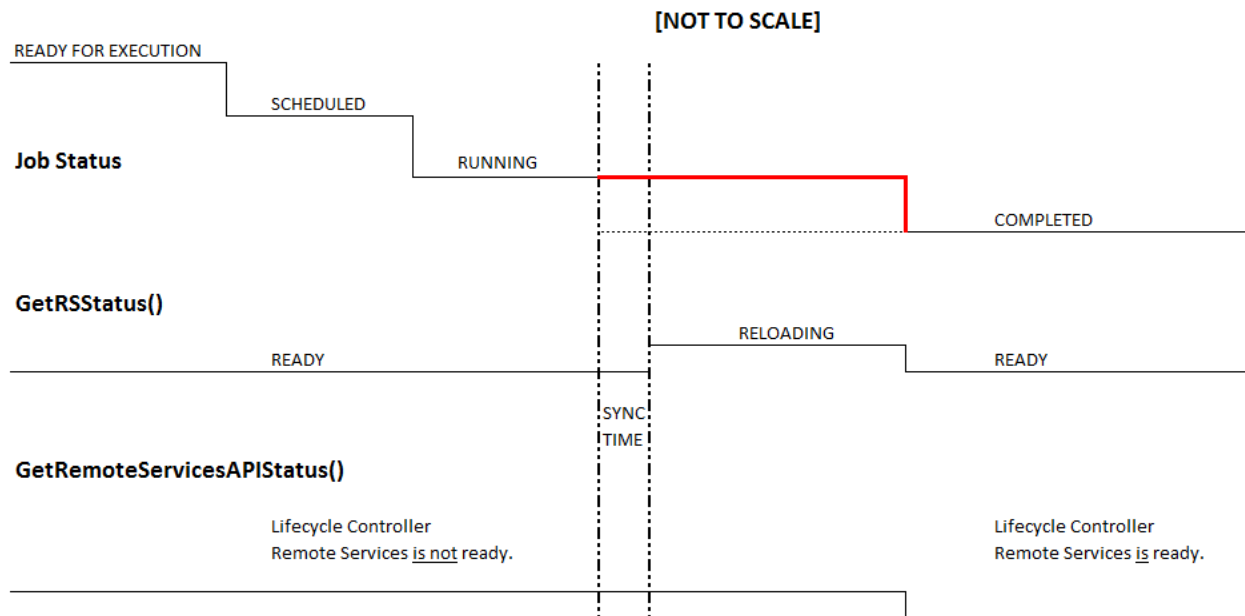

Note: Dotted lines denote the old behavior. Bold red lines denote the new behavior in 12G.

After the job is complete in the Automated Task Application, those jobs that require a refresh - jobs that have message IDs -JOB_SUCCESS and JOB_COMPLETED_ERROR will be kept in RUNNING state till the new sync comes in and the Data Manager is moved to READY state.

Jobs that don't require a refresh will be moved to complete immediately once the job is complete in the Automated Task Application.

1.7.3 11G and 12G compatibility

Figure 3. Compatibility with 11G Workflows

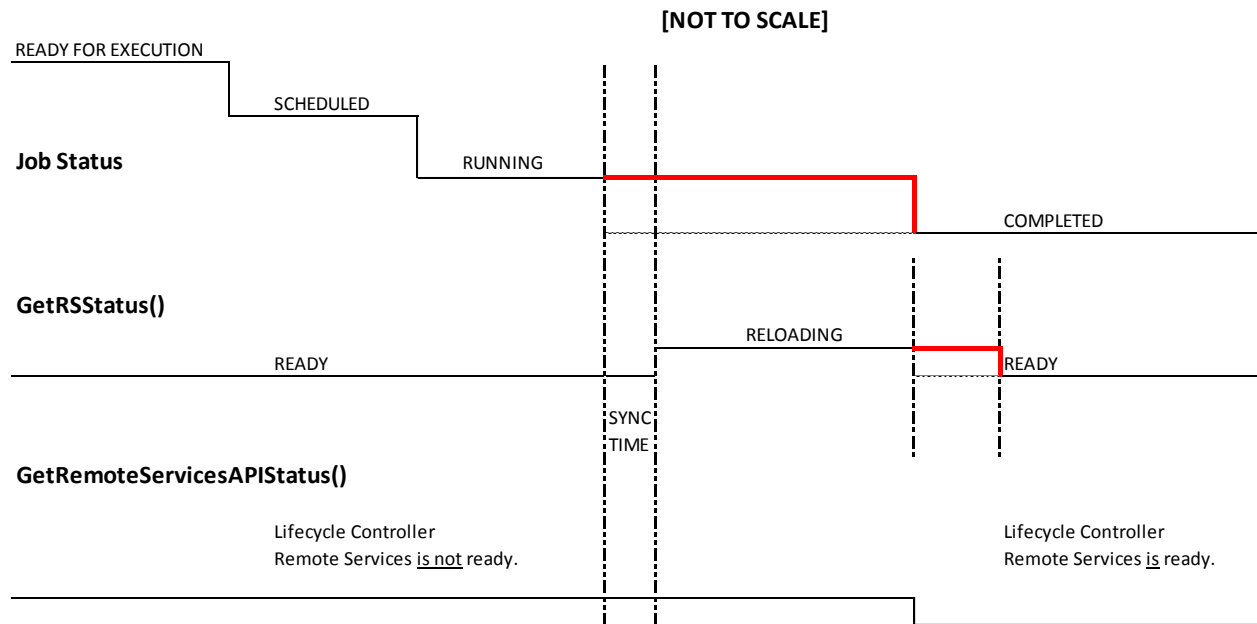

NOTE: Dotted lines denote the old behavior. Bold red line denotes the new behavior in 12G.

The existing 11G workflows expect the RS status to be in RELOADING state once the job is marked COMPLETED. So to maintain the compatibility with the 11G workflows, the RS status is artificially held in the RELOADING state for 90 seconds even though it is actually READY. This time limit was provided by the console team.

1.7.4 GetRemoteServicesAPIStatus output descriptions

Output parameter Name	Possible values	Description
Status	0 (Ready)	Lifecycle Controller Remote Services is ready to accept any web services request.
	1 (Not Ready)	Lifecycle Controller Remote Services is currently not ready to accept web services request. This could be because the instrumentation in iDRAC might be reloading /not_ready or server is in POST or performing scheduled provisioning requests or Lifecycle Controller Unified Server Configurator is in use.
MessageID	LC060	
	LC061	
Message	Lifecycle Controller Remote Services is not ready.	Message for ID LC060
	Lifecycle Controller Remote Services is ready.	Message for ID LC061
ServerStatus	0 (Powered off)	Server is powered off
	1 (In POST)	Server is performing normal POST operation
	2 (Out of POST)	Server is out of POST
	3 (Collecting System Inventory)	Server is currently executing UEFI Collect System Inventory On Restart application
	4 (Automated Task Execution)	Server is currently executing scheduled jobs using UEFI Automated Task application
	5 (Lifecycle Controller Unified Server Configurator)	Server is executing UEFI Lifecycle Controller Unified Server Configurator application
LCStatus	0 (Ready)	Lifecycle Controller instrumentation is up to date and enabled
	1 (Not Initialized)	Lifecycle Controller instrumentation is not initialized. The initialization operation may take up to a minute.
	2 (Reloading Data)	Lifecycle Controller instrumentation is currently refreshing its cache because of a recent configuration change. The reloading operation typically takes few seconds and could take up to few minutes to complete.
	3 (Disabled)	Lifecycle Controller is disabled on the server. Lifecycle Controller can be enabled thru Remote Services or F2 iDRAC configuration.
	4 (In Recovery)	Lifecycle Controller is in Recovery mode. Refer to iDRAC users guide on instructions on how to repair Lifecycle Controller.
	5 (In Use)	Lifecycle Controller is being currently used by another process.

1.8 Reference links

Web Services Interface Guide for Windows & linux

- <http://www.delltechcenter.com/page/Lifecycle+Controller>

Profiles

- <http://en.community.dell.com/techcenter/systems-management/w/wiki/1906.aspx>

PCI ID reference list

- <http://pciids.sourceforge.net/pci.ids>

Installation and Configuration for Windows Remote Management

- [http://msdn.microsoft.com/en-us/library/windows/desktop/aa384372\(v=vs.85\).aspx](http://msdn.microsoft.com/en-us/library/windows/desktop/aa384372(v=vs.85).aspx)

2 Terms and Definitions

2.1	LC
	Lifecycle Controller
2.2	ENUMERATE
	Refers to WS-MAN <code>ENUMERATE</code> operation as described in Section 8.2 of DSP0226_V1.1 and Section 9.1 of DSP0227_V1.0
2.3	GET
	Refers to WS-MAN <code>GET</code> operation as defined in Section 7.3 of DSP00226_V1.1 and Section 7.1 of DSP0227_V1.0
2.4	iDRAC
	integrated Dell Remote Access Controller – management controller for blades and monolithic servers
2.5	USC
	Unified Server Configurator
2.6	iSCSi
	Internet Small Computer System Interface, an Internet Protocol (IP)-based storage networking standard for linking data storage facilities.
2.7	SSM
	System Services Manager
2.8	CSIOR
	Collect System Inventory on Restart
2.9	SSIB
	System Services Information Block
2.10	UEFI
	Unified Extensible Firmware Interface
2.11	BIOS
	Basic Input / Output System
2.12	NIC
	Network Interface Controller
2.13	FQDD
	Fully Qualified Device Description
2.14	LCL
	Lifecycle Log
2.15	WSIG
	Web Services Interface Guide

3 Anomalous Algorithms and Descriptions

3.1 Setting CNA bandwidth

The recommended algorithm is to schedule jobs such that MinBandwidths are first reduced, and then increased. Essentially, delta values need to be sorted, and jobs scheduled in that order.

Consider the following example:

Current: 25, 25, 25, 25

Target: 30, 30, 20, 20

Since 20, 20 are both reducing values from 25, they should be scheduled first. This makes space for increasing the other values. Next, values being increased can be scheduled - 30, 30.

A more complex example:

FQDD: 1, 2, 3, 4

Current: 5, 5, 50, 40

Target: 40, 50, 5, 5

Deltas: -35, -45, 45, 35

Order of job FQDDs: 3, 4, 1, 2

MinBandwidth limitations are documented in the Simple NIC Profile in section 6.7.

<http://attachments.wetpaintserv.us/chcAMan6fnC1y8Z8qYSnag350700>

3.2 iDRAC cloning

Blade cloning consists of a *pull*, enumerating attributes, and a *push*, applying attributes. The **pull** command is a basic enumeration command using the *DCIM_iDRACCardAttribute* class.

Applies to: LC2+

Script: iDRACClonePull.win

- A) The remote service must be in a “ready” state before executing any other WSMAN commands. The GetRSSStatus() method or the GetRemoteServicesAPIStatus() method may be used depending on the version of the LC Management registered profile.
- B) `ENUMERATE` the *DCIM_iDRACCardAttribute* class (same as *DCIM_iDRACCardEnumeration* class) and store the results to be pushed. See section 2.2 for a definition of `ENUMERATE`.

The blade cloning *push* requires an extended WSMAN timeout of 120 seconds, versus the default of 60 seconds. This is needed because of the numerous amounts of attributes that need to be applied.

Below are Windows (winRM) and Linux (wsman) examples that apply all the iDRAC attributes. Replace [IP_ADDRESS], [USER_NAME], and [PASS_WORD] with the actual IP address, username, and password.

winRM format:

```
winrm i ApplyAttributes http://schemas.dmtf.org/wbem/wscim/1/cim-schema/2/root/dcim/DCIM\_iDRACCardService?SystemCreationClassName=DCIM\_ComputerSystem+CreationClassName=DCIM\_iDRACCardService+SystemName=DCIM:ComputerSystem+Name=DCIM:iDRACCardService -u: [USER_NAME] -p:[PASSWORD] -r:https://[IP_ADDRESS]/wsman -SkipCNcheck -SkipCAcheck -encoding:utf-8 -a:basic -timeout:120000 -file:iDRAC.Embedded.1_setatts.xml
```

WSMAN format:

```
wsman invoke -a ApplyAttributes -h [IP_ADDRESS] -P 443 -u [USER_NAME] -p [PASSWORD] -N root/dcim -c /gr2host.cert -y basic http://schemas.dmtf.org/wbem/wscim/1/cim-schema/2/root/dcim/DCIM\_iDRACCardService?SystemCreationClassName="DCIM\_ComputerSystem",SystemName="DCIM:ComputerSystem",CreationClassName="DCIM\_iDRACCardService",Name="DCIM:iDRACCardService" -t 120000 -J iDRAC.Embedded.1_setatts.xml
```

Partial Example of iDRAC.Embedded.1_setatts.xml

```
<p:ApplyAttributes_INPUT
xmlns:p="http://schemas.dmtf.org/wbem/wscim/1/cim-schema/2/root/dcim/DCIM_iDRACCardService">

<p:Target>iDRAC.Embedded.1</p:Target>

<p:AttributeName>Info.1#Product</p:AttributeName>

<p:AttributeName>Info.1#Version</p:AttributeName>

...

<p:AttributeValue>Integrated Dell Remote Access
Controller</p:AttributeValue>

<p:AttributeValue>1.0.0</p:AttributeValue>

</p:ApplyAttributes_INPUT>
```

3.3 Setting NIC string attributes to blank

An issue exists when setting NIC String parameters, such as *IscsiInitiatorName*, using the NIC menu (usually entered via ctrl-s) from a non-blank value to a blank value.

As a result, when the NIC is used for operations that utilize this parameter, such as iscsi boot, the operation will be unsuccessful because it will use the old value instead of the one displayed through WSMAN.

The work around for this scenario is to *not* set any NIC String parameters to a blank value.

3.4 Determine NIC card

There are two different ways to determine the model/type of a NIC card:

- 1) ENUMERATE the *DCIM_NICView* class and note the PCID, then look up in PCID table <http://pciids.sourceforge.net/pci.ids>
- 2) ENUMERATE the *DCIM_NICString* class and search for attribute *ChipMdl*. The *CurrentValue* parameter will contain the NIC card model number.

DCIM_NICString

```
AttributeName = ChipMdl
CurrentValue = BCM5716 C0
DefaultValue
FQDD = NIC.Embedded.2-1
InstanceID = NIC.Embedded.2-1:ChipMdl
IsReadOnly = true
MaxLength = 0
MinLength = 0
PendingValue
```

3.5 List of partitionable NIC cards for LC2

The following is a list of partitionable NICs supported by LC2.

Broadcom

57810 bNDC - JVFVR
57810 SFP+ NIC - N20KJ
57810 Base-T NIC - W1GCR
57810 Mezz - 55GHP
57800 rNDC - MT09V

QLogic

QMD8262 bNDC - D90TX
QLE8262 NIC - JHD51
QME8262 Mezz - 9Y65N

3.6 iDRAC Telnet attribute enables SerialRedirection

The following behavior describes a situation where setting certain iDRAC attribute(s) causes another iDRAC attribute to automatically and simultaneously change.

Setting any of the following *Telnet* attributes causes the *SerialRedirection* attribute to become *Enabled*.

- Port [InstanceID = iDRAC.Embedded.1#Telnet.1#Port]
- Enable [InstanceID = iDRAC.Embedded.1#Telnet.1#Enable]
- Timeout [InstanceID = iDRAC.Embedded.1#Telnet.1#Timeout]

Recommendation:

Change the Telnet attributes prior to setting the *SerialRedirection.Enable* attribute. Or, if using input XML, have the Telnet attributes before the *SerialRedirection.Enable* attribute.

3.7 Never unplug hardware during updates

Users should not unplug any hardware during critical remote enablement (RE) updates. This may result in unexpected behaviors.

As an example, unplugging a USB key during critical updates may cause a Red Screen of Death (RSOD).

3.8 Express versus Enterprise iDRACs

There are four levels of iDRAC licensing as follows:

- 1) Basic
- 2) Express (Monolithic)
- 3) Express for blades(Modular)
- 4) Enterprise

One method of determining the level on a system is to perform an enumeration of the DCIM_iDRACCardView class. Example results are shown for reference.

Monolithic:

```
DCIM_iDRACCardView
  FQDD = iDRAC.Embedded.1-1
  FirmwareVersion = 1.00.00
  GUID = 3132334f-c0b7-3480-3510-00364c4c454
  IPMIVersion = 2.0
  InstanceID = iDRAC.Embedded.1-1#iDRACinfo
  LANEnabledState = 1
  LastSystemInventoryTime = 20120302092309.000000+000
  LastUpdateTime = 20120305233206.000000+000
  Model = Enterprise
  PermanentMACAddress = 78:2b:cb:54:54:11
  ProductDescription = This system component provides a complete set of remote management
  functions
  for Dell PowerEdge servers
  SOLEnabledState = 1
```

Modular:

```
DCIM_iDRACCardView
  FQDD = iDRAC.Embedded.1-1
```

FirmwareVersion = 1.00.00
GUID = 3132334f-c0b7-3480-3510-00364c4c454
IPMIVersion = 2.0
InstanceID = iDRAC.Embedded.1-1#iDRACinfo
LANEnabledState = 1
LastSystemInventoryTime = 20120121022852.000000+000
LastUpdateTime = 20120124015120.000000+000
Model = Express for Blades
PermanentMACAddress = d0:67:e5:f4:2f:97
ProductDescription = This system component provides a complete set of remote management functions for Dell PowerEdge servers
SOLEnabledState = 1

3.9 CIM Query Language (CQL) Filters

The CIM Query Language (CQL) is a query language for the Common Information Model (CIM) standard from the Distributed Management Task Force (DMTF). It was designed to perform queries against the CIM objects in a database.

3.9.1 CQL filter benefits

The two most distinct advantages of using CQL filters when performing enumerations are:

- The response time of enumerations will be accelerated as only the desired data is returned, not the full data set.
- The workload on the network will be decreased as less bandwidth will be consumed per enumeration as the amount of data being returned is less. This is more applicable to networks that may have many systems that performing enumerations at or about the same time.

3.9.2 How to perform CQL enumerations using RECITE

Section 1.2 describes how to setup and run scripts using the RECITE PYTHON environment. Running CQL filters requires running the CQL command directly from the RECITE command line. No scripts exist because of the infinite number of use cases.

3.9.3 CQL filter example that enumerates all NIC attributes for a particular port/partition

The FQDD in the example below will be unique to a particular user's system. The NIC FQDDs of the system can be obtained by running the GetNICViews() command from the RECITE command line.

```
GetNICAttributes -cql="select * from DCIM_NICAttribute where  
FQDD='NIC.Integrated.1-1-1'"
```

3.9.4 CQL filter example that enumerates all iDRAC attributes with a particular GroupDisplayName and AttributeName

The GroupDisplayName and the AttributeName in the example below will be unique to a particular user's system.

```
GetiDRACCardAttributes -cql="select * from DCIM_iDRACCardAttribute where  
GroupDisplayName='iDRAC Users' and AttributeName='UserName'"
```

3.9.5 CQL filter example that enumerates all BIOS attributes where the IsReadOnly flag is set to TRUE

The expression below return attributes that have the IsReadOnly=TRUE flag set as the CurrentValue.

```
GetBIOSEnumerations -cql="select CurrentValue from DCIM_BIOSEnumeration where  
IsReadOnly=TRUE"
```

3.10 Ordering of iDRAC attributes to set or apply (11G vs 12G)

Users need to correctly set the order in which iDRAC, System, and LC attributes are applied. Incorrect ordering of attributes may result in an error, if dependencies are violated. The DisplayOrder field of each attribute along with the applicable references in profiles, provide direction as to the appropriate ordering.

An example would be to create an iDRAC user account. On 11G systems, the iDRAC would automatically re-order the the attributes before setting/applying them to create and enable a user account. However, due to the expansion of attributes in 12G systems as well as to avoid the anticipating the user's intent, re-ordering of attributes was removed.

The correct order for setting iDRAC attributes when enabling a user account on both 11G and 12G is as follows:

1. Username

2. Password
3. <other attributes>

This ordering is applicable to both ApplyAttributes() and SetAttributes() iDRAC methods. Use the reverse order when clearing/disabling the account.

3.11 How to determine if server is 11G or 12G

In order to determine if a server is 11G or 12G irrespective of the license present on the server, the recommendation is to look at “LifecycleControllerVersion” property from DCIM_SystemView. If this property is not shown or the value is 1.x.y then it is 11G system. If the value is 2.x.y then it is 12G.

Section 31.4 of this document describes the workflow for enumerating the DCIM_SystemView class.

3.12 Using special characters in usernames

For 11G systems, usernames may not contain the characters: <, >, ‘, /.

For 12G systems, usernames may not contain the characters: /, \, @, ., !.

When an iDRAC user has angle brackets for the username or password, they must use double quotes around the brackets when trying to execute any WSMAN commands.

3.13 Obtaining Updated System Inventory

Use the following procedure below to refresh stale inventory or to ensure the inventory has the most up to date information. Collect System Inventory on Restart (CSIOR) is the mechanism which checks and updates the inventory. CSIOR is run, when enabled, during the boot process.

Applies to: LC1.3.0+

- A) [LC1.5.0+] The Lifecycle Controller remote service must be in a “ready” state before executing any other WSMAN commands. The GetRSStatus() method or the GetRemoteServicesAPIStatus() method may be used depending on the version of the LC Management registered profile.
- B) Ensure CSIOR attribute is enabled
 - See Section 31.3 to Check and enable Collect System Inventory on Restart (CSIOR)
- C) Power on or reboot system

- NOTE: If an operating system has been installed, the system will boot into it. It may be desired to wait until the OS boot is complete before performing a graceful shutdown.
- D) [LC1.5.0+] The Lifecycle Controller remote service must be in a “ready” state before executing any other WSMAN commands. The GetRSStatus() method or the GetRemoteServicesAPIStatus() method may be used depending on the version of the LC Management registered profile.
- When the system is ready, the inventory is updated

3.14 How to determine if the system is blade, tower, or rack

Dell has been officially using “M”, “T” and “R” letters in the Model name to distinguish between “Modular”, “Tower” and “Rack” server respectively for the past couple of generations.

Getting the *SystemGeneration* attribute can be achieved by viewing the SystemView class. Section 31.4 of this document describes the workflow for enumerating the DCIM_SystemView class.

Examples below:

- 11G Blades: M610, M710, M910
- 12G Blades: M420, M520, M820
- 11G Towers: T310, T410, T610
- 12G Towers: T320, T420, T620
- 11G Racks: R310, R410, R610
- 12G Racks: R320, R520, R820

3.15 Getting the SystemID, Model, and more

Section 31.4 of this document describes the workflow for enumerating the DCIM_SystemView class. Example data returned is shown below.

```
DCIM_SystemView
AssetTag = tag
BIOSReleaseDate = 08/20/2012
BIOSVersionString = 1.3.5
BaseBoardChassisSlot = NA
BatteryRollupStatus = 1
BladeGeometry = 4
BoardPartNumber = 0N051FX02
BoardSerialNumber = CN1374092O003M
CMCIP
CPLDVersion = 0.4.7
CPURollupStatus = 1
ChassisName = Main System Chassis
ChassisServiceTag = S78FGH5
ChassisSystemHeight = 1
ExpressServiceCode = 61387326761
FQDD = System.Embedded.1
FanRollupStatus = 3
HostName
InstanceID = System.Embedded.1
LastSystemInventoryTime = 20130206014757.000000+000
```

LastUpdateTime = 20130206004538.000000+000
LicensingRollupStatus = 1
LifecycleControllerVersion = 2.1.0
Manufacturer = Dell Inc.
MaxCPUSockets = 2
MaxDIMMSlots = 24
MaxPCleSlots = 3
MemoryOperationMode = MirrorMode
Model = PowerEdge R620
PSRollupStatus = 1
PlatformGUID = 3548474f-c0d3-4680-3810-00374c4c4544
PopulatedCPUSockets = 1
PopulatedDIMMSlots = 2
PopulatedPCleSlots = 0
PowerCap = 340
PowerCapEnabledState = 3
PowerState = 2
PrimaryStatus = 3
RollupStatus = 3
ServerAllocation
ServiceTag = S78FGH5
StorageRollupStatus = 1
SysMemErrorMethodology = 6
SysMemFailOverState = NotInUse
SysMemLocation = 3
SysMemMaxCapacitySize = 786432
SysMemPrimaryStatus = 1
SysMemTotalSize = 2048
SystemGeneration = 12G Monolithic
SystemID = 1230
SystemRevision = 0
TempRollupStatus = 1
UUID = 4c4c4544-0037-3810-8046-d3c04f474835
VoltRollupStatus = 1
smbiosGUID = 44454c4c-3700-1038-8046-d3c04f474835

3.16 Http, CIFS, NFS, tftp, ftp formatting

Various protocols are required for methods accessing and/or writing to network shares. The format for these protocols are summarized below.

HTTP Format:

http://[IP ADDRESS]/[PATH TO FILE.exe]

CIFS or NFS Format:

cifs://[WORKGROUP_NAME]\[USERNAME]:[PASSWORD]@[URI-IP-ADDRESS]/
[FILE.exe];mountpoint=[DIRECTORYNAME]

TFTP or FTP Format:

tftp://[IP ADDRESS]/[PATH TO FILE.exe]

ftp://[IP ADDRESS]/[PATH TO FILE.exe]

4 Workflows

The Best Practice Guide provides the detailed step-by-step Lifecycle Controller WSMAN API interactions and algorithmic descriptions needed to implement various system management workflows.

4.1 RAID stacking: ResetConfig, CreateVD, assign HotSpares

This workflow stacks multiple RAID operations together and is applied immediately using the TIME_NOW parameter, which requires one reboot operation. The workflow deletes existing virtual disks and unassigns all hotspares before creating a single virtual disk, a dedicated hotspare, and a global hotspare. Following completion of the reboot, the new virtual disk and hotspare results will be verified. Approximate time for completion on a 12G system is 15 minutes.

Applies to: LC1.5.1+

Prerequisites for script:

- Set FQDD of desired RAID controller by editing the following script
- Applicable RAID controller and hard drives

Script: RAIDstacking_TIME_NOW.win

- A) The Lifecycle Controller remote service must be in a “ready” state before executing any other WSMAN commands. The GetRSSStatus() method or the GetRemoteServicesAPIStatus() method may be used depending on the version of the LC Management registered profile.
- B) [LC1.5.1 only] Disable CSIOR (Collect System Inventory on Restart).

NOTE: On 11G systems, CSIOR must be disabled to circumvent a sync behavior that prohibits successful RAID stacking.

- a. SetLCAttribute(): Sets attribute to be configured [ReturnValue=0]
- b. CreateConfigJob(): Creates jobId and applies configuration [ReturnValue=4096]
- C) ENUMERATE the *DCIM_ControllerView* class to find RAID controller’s instanceID & FQDD (They are often identical.) See section 2.2 for a definition of ENUMERATE .
- a. Integrated RAID card example is ”RAID.Integrated.1-1”
- b. External RAID card example is ”RAID.Slot.1-1”
- D) ResetConfig(): Delete all virtual disks and unassign all HotSpare physical disks. [ReturnValue=0]
- E) CreateVirtualDisk(): RAID 1 on physical disk 0 & 1, for example. [ReturnValue=0].

- F) AssignSpare(): Create dedicated hotspare using Create VD instanceID [ReturnValue=0].
- G) AssignSpare(): Create global hotspare [ReturnValue=0].
- H) CreateRAIDConfigJob(): Apply steps D) - F) [ReturnValue=4096].
- I) Poll jobstatus for Completed: GET the InstanceID of from H). See section 2.3 for a definition of GET .
- J) The Lifecycle Controller remote service must be in a “ready” state before executing any other WSMAN commands. The GetRSStatus() method or the GetRemoteServicesAPIStatus() method may be used depending on the version of the LC Management registered profile.

The GetRSStatus() method must first poll for ‘reloading’ then poll for ‘ready’, while the GetRemoteServicesAPIStatus() can just poll for ‘ready.’
- K) ENUMERATE the *DCIM_VirtualDiskView* class to ensure successful virtual disk creation. See section 2.2 for a definition of ENUMERATE .
 - a. RAIDTypes parameter will be 4, for a RAID 1 configuration
 - b. PhysicalDiskIDS parameter will list physical disks used
- L) ENUMERATE the *DCIM_PhysicalDiskView* class to ensure successful hotspare assignments. See section 2.2 for a definition of ENUMERATE .
 - a. HotSpareStatus parameter of 2, indicates global hotspare
 - b. HotSpareStatus parameter of 1, indicates dedicated hotspare

NOTE: H200 controller is unique in that it always returns 2 for both dedicated and global hotspares

4.2 RAID stacking with BIOS attributes using Setupjobqueue

This workflow stacks multiple RAID operations together along with some BIOS attributes, which requires one reboot operation using setupjobqueue. The workflow deletes existing virtual disks, and unassigns all hotspares before creating a single virtual disk and a dedicated hotspare. Multiple EmbNIC BIOS attributes are also set to **Enabled**. Following completion of the reboot, the new virtual disk, hotspare, and BIOS attributes results will be verified. Approximate time for completion on a 12G system is 15 minutes.

Applies to: LC1.5.1+

Prerequisites for script:

- Set FQDD of desired RAID controller by editing the following script
- Applicable RAID controller and hard drives

Script: RAIDstacking_BIOS_setupjobqueue.win

- A) The Lifecycle Controller remote service must be in a “ready” state before executing any other WSMAN commands. The GetRSStatus() method or the GetRemoteServicesAPIStatus() method may be used depending on the version of the LC Management registered profile.

- B) [LC1.5.1 only] Disable CSIOR (Collect System Inventory on Restart).
NOTE: On 11G systems, CSIOR must be disabled to circumvent a sync behavior that prohibits successful RAID stacking.
- a. SetAttribute(): Sets attribute to be configured [ReturnValue=0]
 - b. CreateConfigJob(): Creates jobID and applies configuration [ReturnValue=4096]
- C) ENUMERATE the *DCIM_ControllerView* class to find RAID controller's instanceID & FQDD (they are often identical.) See Section 2.2 for a definition of ENUMERATE .
- a. Integrated RAID card example is "RAID.Integrated.1-1"
 - b. External RAID card example is "RAID.Slot.1-1"
- D) ResetConfig(): Delete all virtual disks and unassign all HotSpare physical disks. [ReturnValue=0].
- E) CreateVirtualDisk(): RAID 1 on physical disk 0 & 1, for example. [ReturnValue=0].
- F) AssignSpare(): Create dedicated hotspare using Create VD instanceID [ReturnValue=0].
- G) CreateRAIDConfigJob(): Apply steps D) - F) without reboot type, without UntilTime, and without ScheduledStartTime parameter TIME_NOW. [ReturnValue=4096].
- H) SetAttribute(): Set BIOS attribute EmbNic1Nic2 to Enabled [ReturnValue=0]
- I) CreateBIOSConfigJob(): Apply step H) without reboot type, without UntilTime, and without ScheduledStartTime parameter TIME_NOW. [ReturnValue=4096]
- J) CreateRebootJob(): Pass RebootJobType of 3 parameter
- 1 = PowerCycle
 - 2 = Graceful reboot without forced shutdown
 - 3 = Graceful reboot with forced shutdown
- K) SetupJobQueue(): Use RAID JID(G), BIOS JID(J), and reboot RID(K) [ReturnValue=0]
- L) Poll jobstatus for Completed: GET the InstanceID of from G) or J). See section 2.3 for a definition of GET .
- M) The Lifecycle Controller remote service must be in a "ready" state before executing any other WSMAN commands. The GetRSStatus() method or the GetRemoteServicesAPIStatus() method may be used depending on the version of the LC Management registered profile.
- The GetRSStatus() method must first poll for 'reloading' then poll for 'ready', while the GetRemoteServicesAPIStatus() can just poll for 'ready.'
- N) ENUMERATE the *DCIM_VirtualDiskView* class to ensure successful virtual disk creation. See section 2.2 for a definition of ENUMERATE .
- a. RAIDTypes parameter will be 4, for a RAID 1 configuration
 - b. PhysicalDiskIDS parameter will list physical disks used
- O) ENUMERATE the *DCIM_PhysicalDiskView* class to ensure successful hotspare assignments. See section 2.2 for a definition of ENUMERATE .

- a. HotSpareStatus parameter of 2, indicates global hotspare
- b. HotSpareStatus parameter of 1, indicates dedicated hotspare
NOTE: H200 controller is unique in that it always returns 2 for both dedicated and global hotspares

P) ENUMERATE the *DCIM_BIOSEnumeration* class to ensure BIOS settings were correctly set.
See section 2.2 for a definition of ENUMERATE .

4.3 Boot to network ISO

This workflow boots the host system from an image on a network share. The workflow first removes any existing driver packs or existing attached OS, then gets available OS drivers, unpacks the desired set of drivers, and boots from an image on a network share. Approximate time for completion on a 12G system is 20-40 minutes depending on the size of the driver pack that will be unpacked and the speed of the network to boot image.

Applies to: LC1.3.0+

Prerequisites for script:

- Place applicable ISO image in applicable network share
- Set script variables by editing script

Script: BootToNetworkISO.win

A) The Lifecycle Controller remote service must be in a “ready” state before executing any other WSMAN commands. The GetRSStatus() method or the GetRemoteServicesAPIStatus() method may be used depending on the version of the LC Management registered profile.

NOTE: GetRemoteServicesAPIStatus() will return “not ready” if drivers or an ISO is already attached.

B) DetachDrivers(): Ensures any drivers are detached.

C) DetachISOImage(): Ensures all images are detached.

D) GetDriverPackInfo(): Displays available OS drivers. This is only required for end to end OS deployment.

E) UnpackAndAttach(): Unpacks and attaches desired driver pack. The resulting concrete job is invoked immediately. This is only required for end to end OS deployment.

F) Poll concrete job until ‘Success’.

G) BootToNetworkISO(): The resulting concrete job is invoked immediately.

H) Poll concrete job until ‘Success’.

NOTE: OS is still booting at this point, so sleep to allow completion. Steps I) through J) are provided when the BootToNetwork image is no longer desired.

I) DetachDrivers(): [ReturnValue=0].

J) DetachISOImage(): [ReturnValue=0].

K) RequestMonoSystemStateChange(): [ReturnValue=0].

NOTE: Modular systems (i.e. M610, M710, etc.) use RequestModSystemStateChange().

4.4 Boot to ISO from vFlash

This workflow boots the host system from an ISO image located on the vFlash. The workflow first removes any existing driver packs or existing attached OS, then gets available OS drivers, unpacks the desired set of drivers, and boots from an image on the vFlash. Approximate time for completion on an 12G system is 20-40 minutes depending on the size of the driver pack to unpack.

Applies to: LC1.3.0+

Prerequisites for script:

- Place applicable ISO image in applicable network share
- Set script variables by editing script

Script: BootTovFlash.win

A) The Lifecycle Controller remote service must be in a “ready” state before executing any other WSMAN commands. The GetRSStatus() method or the GetRemoteServicesAPIStatus() method may be used depending on the version of the LC Management registered profile.

NOTE: GetRemoteServicesAPIStatus() will return “not ready” if drivers or an ISO is already attached.

B) DetachDrivers(): Ensures any previous drivers are detached.

C) DetachISOImage(): Ensures all previous images are detached.

D) DetachISOFromVFlash(): Ensures all previous images are detached.

E) DeleteISOFromVFlash(): Ensures all previous images are deleted.

F) DownloadISOToVFlash(): Download desired image from network to vFlash.

G) Poll concrete job until ‘Success’.

H) GetDriverPackInfo(): Displays available OS drivers. This is only required for end to end OS deployment.

I) UnpackAndAttach(): Unpacks and attaches desired driver pack. The resulting concrete job is invoked immediately. This is only required for end to end OS deployment.

J) Poll concrete job until ‘Success’.

K) BootToISOFromVFlash(): The resulting concrete job is invoked immediately.

L) Poll concrete job until ‘Success’.

NOTE: OS boot is complete at this point, sleep 600 seconds to allow for completion. Steps M) through P) are providing when the BootToNetwork image is no longer desired.

M) DetachDrivers(): [ReturnValue=0].

- N) DetachISOFromVFlash(): [ReturnValue=0].
- O) DeleteISOFromVFlash(): [ReturnValue=0].
- P) RequestMonoSystemStateChange(): Reboot to finish removal of OS [ReturnValue=0].

NOTE: Modular systems (i.e. M610, M710, etc.) use RequestModSystemStateChange().

4.5 Set hard drive to first in boot order

This workflow will set the hard drive(c:) to the top of the boot order. If the BootMode is set to UEFI, it will set it to BIOS. Following completion of the reboot, the hard drive will be enabled and set to boot first. Approximate time for completion that one can expect to encounter on an 12G system is 15-25 minutes, depending on whether an additional reboot is needed to set the BootMode parameter.

Applies to: LC1.4.0+

Prerequisites for script: None

Script: Set_HD_Boot.win

- A) The Lifecycle Controller remote service must be in a “ready” state before executing any other WSMAN commands. The GetRSStatus() method or the GetRemoteServicesAPIStatus() method may be used depending on the version of the LC Management registered profile.
- B) Change BootMode to BIOS, if current value is UEFI.
 - a. SetAttribute(): Sets attribute to be configured [ReturnValue=0]
 - b. CreateBIOSConfigJob(): Creates jobID and applies configuration [ReturnValue=4096]
- C) GetBootConfigSettings(): ENUMERATE the *DCIM_BootConfigSetting* class to identify the *ElementName* field containing *BootSeq* and corresponding *InstanceID* (IPL or UEFI). See section 2.2 for a definition of ENUMERATE .
 - ElementName = Hard drive C: BootSeq
- D) GetBootSourceSettings(): ENUMERATE the *DCIM_BootSourceSetting* class. See section 2.2 for a definition of ENUMERATE .
 - a. The *CurrentAssignedSequence* attribute of each instance defines the instance’s place in the zero based indexed boot sequence
 - b. The *CurrentEnabledStatus* attribute defines whether the boot source, such as the hard drive, is enabled
 - c. If the current sequence is 0 and the status is enable, skip to the end
- E) ChangeBootOrderByInstanceID(): using instanceID = IPL [ReturnValue=0]
- F) ChangeBootSourceState(): using instanceID = IPL and EnabledState=1 [ReturnValue=0]
- G) Poll jobstatus for Completed: GET the *InstanceID* of from E). See section 2.3 for a definition of GET .

- H) The Lifecycle Controller remote service must be in a “ready” state before executing any other WSMAN commands. The `GetRSStatus()` method or the `GetRemoteServicesAPIStatus()` method may be used depending on the version of the LC Management registered profile.

The `GetRSStatus()` method must first poll for ‘reloading’ then poll for ‘ready’, while the `GetRemoteServicesAPIStatus()` can just poll for ‘ready.’

- I) `ENUMERATE` the `DCIM_BootSourceSetting` class. See section 2.2 for a definition of `ENUMERATE`.
- a. The `CurrentAssignedSequence` of the “Hard drive C” should be 0
 - b. The `CurrentEnabledStatus` of the “Hard drive C” should be 1

4.6 Export (backup) image to vFlash

This workflow performs a backup, or export operation, which saves the image to the vFlash. The `TIME_NOW` parameter is passed, which invokes the operation immediately. Approximate time for completion on an 12G system is 20-50 minutes depending on the system configuration.

Applies to: LC1.5.0+

Prerequisites for script:

- Valid and enabled vFlash card for licensing
- [optional] Change passphrase by editing script

Script: Backup_vFlash.win

- A) The Lifecycle Controller remote service must be in a “ready” state before executing any other WSMAN commands. The `GetRSStatus()` method or the `GetRemoteServicesAPIStatus()` method may be used depending on the version of the LC Management registered profile.
- B) `BackupImage()`: Performs backup operation [`ReturnValue=4096`].
- C) Poll jobstatus for Completed: `GET` the `InstanceID` of from B). See section 2.3 for a definition of `GET`.

NOTE: The available space on the SD card will be reduced by 384MB upon completion of successful backup.

4.7 Export (backup) image to CIFS or NFS share

This workflow performs a backup, or export operation, which saves the image to a CIFS or NFS share. The `TIME_NOW` parameter is passed, which invokes the operation immediately. Approximate time for completion on a 12G system is 20-50 minutes depending on the system configuration.

NOTE: The export operation will overwrite an existing backup image on a network share if an identical name is used.

Applies to: LC1.5.0+

Prerequisites for script:

- Valid and enabled vFlash card for licensing
- Set script variables by editing script

Script: Backup_CIFS_NFS.win

- A) The Lifecycle Controller remote service must be in a “ready” state before executing any other WSMAN commands. The GetRSStatus() method or the GetRemoteServicesAPIStatus() method may be used depending on the version of the LC Management registered profile.
- B) BackupImage(): Performs backup operation [ReturnValue=4096].
- C) Poll jobstatus for Completed: GET the InstanceID of from B). See section 2.3 for a definition of GET .

4.8 Import (restore) image from vFlash

This workflow performs a restore, or import operation, which restores the image from the vFlash. The TIME_NOW parameter is passed, which invokes the operation immediately. Approximate time for completion on an 12G system is 30-60 minutes depending on the system configuration.

Applies to: LC1.5.0+

Prerequisites for script:

- Valid and enabled vFlash card for licensing
- Backup image on SD card (vFlash)
- Passphrase required if backup image used passphrase, edit script

Script: Restore_vFlash.win

- A) The Lifecycle Controller remote service must be in a “ready” state before executing any other WSMAN commands. The GetRSStatus() method or the GetRemoteServicesAPIStatus() method may be used depending on the version of the LC Management registered profile.
- B) RestoreImage(): Performs restore operation [ReturnValue=4096].
- C) Poll jobstatus for Completed: GET the InstanceID of from B). See section 2.3 for a definition of GET .

4.9 Import (restore) image from CIFS or NFS share

This workflow performs a restore, or import operation, which restores an image from the either a CIFS or NFS share. The TIME_NOW parameter is passed, which invokes the operation immediately. Approximate time for completion on an 12G system is 30-60 minutes depending on the system configuration and network.

Applies to: LC1.5.0+

Prerequisites for script:

- Valid and enabled vFlash card with existing image
- Set script variables by editing script

Script: Restore_CIFS_NFS.win

- A) The Lifecycle Controller remote service must be in a “ready” state before executing any other WSMAN commands. The GetRSStatus() method or the GetRemoteServicesAPIStatus() method may be used depending on the version of the LC Management registered profile.
- B) RestoreImage(): Performs restore operation [ReturnValue=4096].
- C) Poll jobstatus for Completed: GET the InstanceID of from B). See section 2.3 for a definition of GET .

4.10 iDRAC firmware DUP update from CIFS or TFTP share

This workflow performs an update of the iDRAC firmware from a DUP by first downloading the DUP to the system, then applying the update. The update of the iDRAC firmware will be invoked after being scheduled using SetupJobQueue. Approximate time for completion is 30-60 minutes depending on the system configuration and network.

Applies to: LC1.3.0+

Prerequisites for script:

- Desired DUP must be present on network share
- Set script variables by editing script

Script: iDRAC_update.win

- A) The Lifecycle Controller remote service must be in a “ready” state before executing any other WSMAN commands. The GetRSStatus() method or the GetRemoteServicesAPIStatus() method may be used depending on the version of the LC Management registered profile.
- B) GetSoftwareIdentities(): ENUMERATE the DCIM_SoftwareIdentity class to list the firmwares on the system. See section 2.2 for a definition of ENUMERATE.
- C) Search the results from B) for:

[LC1.5.0/LC1.5.1] "ElementName = iDRAC6" and note the accompanying instanceID to be used in D).

[LC2 1.0] "ElementName = Integrated Dell Remote Access Controller" and note the accompanying instanceID to be used in D).

Use the Software Inventory registered profile version to determine the applicable string to search for.

- D) InstallFromURI(): Invokes firmware update operation [ReturnValue=4096].
- E) CreateRebootJob(): Pass parameter RebootJobType of value 3.
- 1 = PowerCycle
 - 2 = Graceful reboot without forced shutdown
 - 3 = Graceful reboot with forced shutdown

- F) SetupJobQueue(): Use JID(D) and reboot RID(E) [ReturnValue=0]; The StartTimeInterval parameter is set to TIME_NOW, meaning the operations will be invoked immediately.
- G) Poll RID jobstatus for Reboot Completed: GET the InstanceID of from E). See section 2.3 for a definition of GET .
- H) Poll JID jobstatus for Completed: GET the InstanceID of from D). See section 2.3 for a definition of GET .
- I) The Lifecycle Controller remote service must be in a “ready” state before executing any other WSMAN commands. The GetRSStatus() method or the GetRemoteServicesAPIStatus() method may be used depending on the version of the LC Management registered profile.

4.11 BIOS firmware DUP update from CIFS or TFTP share

This workflow performs an update of the BIOS firmware from a DUP by first downloading the DUP to the system, then applying the update. The update of the BIOS firmware will be invoked after being scheduled using SetupJobQueue. Approximate time for completion is 30-60 minutes depending on the system configuration and network.

Applies to: LC1.3.0+

Prerequisites for script:

- Desired DUP must be present on network share
- Set script variables by editing script

Script: BIOS_update.win

- A) The Lifecycle Controller remote service must be in a “ready” state before executing any other WSMAN commands. The GetRSStatus() method or the GetRemoteServicesAPIStatus() method may be used depending on the version of the LC Management registered profile.
- B) GetSoftwareIdentities(): ENUMERATE the DCIM_SoftwareIdentity class to list the firmwares on the system. See section 2.2 for a definition of ENUMERATE .
- C) Search the results from B) for "ElementName = BIOS" and for "Status = Installed", then note the accompanying instanceID to be used in D)
- D) InstallFromURI(): Invokes firmware update operation [ReturnValue=4096]
- E) CreateRebootJob(): Pass parameter RebootJobType of value 3
 - 1 = PowerCycle
 - 2 = Graceful reboot without forced shutdown
 - 3 = Graceful reboot with forced shutdown
- F) SetupJobQueue(): Use JID(D) and reboot RID(E) [ReturnValue=0]; The StartTimeInterval parameter is set to TIME_NOW, meaning the operations will be invoked immediately
- G) Poll RID jobstatus for Reboot Completed: GET the InstanceID from E). See section 2.3 for a definition of GET .
- H) Poll JID jobstatus for Completed: GET the InstanceID from D). See section 2.3 for a definition of GET .

- I) [LC1.5.0/LC1.5.1] Sleep for 5 minutes to allow reboot, POST, and CSIOR to complete
[See Appendix 33.4.3 and 33.4.7 for more information about POST and CSIOR](#)
- J) The Lifecycle Controller remote service must be in a “ready” state before executing any other WSMAN commands. The GetRSStatus() method or the GetRemoteServicesAPIStatus() method may be used depending on the version of the LC Management registered profile.

4.12 USC firmware DUP update from CIFS or TFTP share

This workflow performs an update of the USC (LC) firmware from a DUP by first downloading the DUP to the system, then applying the update. By design, the update of the USC firmware will be invoked immediately following download completion and cannot be scheduled for a later time. Approximate time for completion is 30-60 minutes depending on the system configuration.

Applies to: LC1.3.0+

Prerequisites for script:

- Desired DUP must be present on network share
- Set script variables by editing script

Script: USC_LC_update.win

- A) The Lifecycle Controller remote service must be in a “ready” state before executing any other WSMAN commands. The GetRSStatus() method or the GetRemoteServicesAPIStatus() method may be used depending on the version of the LC Management registered profile.
- B) GetSoftwareIdentities(): ENUMERATE the *DCIM_SoftwareIdentity* class to list the firmwares of the system. See section 2.2 for a definition of ENUMERATE.
- C) Search the results from B) for "ElementName = Dell Lifecycle Controller" and note the accompanying instanceID to be used in D). There may be additional characters and numbers after the substring “Controller”.
- D) InstallFromURI(): Invokes firmware update operation [ReturnValue=4096]
NOTE: The USC update is applied immediately, and cannot be scheduled for a later time.
- E) Poll jobstatus for Completed: GET the *InstanceID* of from D). See section 2.3 for a definition of GET .
- F) RequestiDRACStateChange(): Must reset idrac for changes to take effect [ReturnValue=0]
- G) [LC1.5.0/LC1.5.1]Sleep for 10 minutes to allow reboot, POST, and CSIOR to complete
[See Appendix 33.4.3 and 33.4.7 for more information about POST and CSIOR](#)
- H) The Lifecycle Controller remote service must be in a “ready” state before executing any other WSMAN commands The GetRSStatus() method or the GetRemoteServicesAPIStatus() method may be used depending on the version of the LC Management registered profile.

4.13 PXE Boot using embedded NICs (11G only)

This workflow performs a reboot of the host OS into the PXE boot configuration by first setting the embNic1Nic2 parent attributes and embNic1 and embNic2 child attributes. Approximate time for completion on an 11G system is 20-40 minutes depending on the system configuration.

Applies to: LC1.5.1+

Prerequisites for script: None

Script: PXEboot_NIC1_NIC2.win

- A) The Lifecycle Controller remote service must be in a “ready” state before executing any other WSMAN commands. The GetRSStatus() method or the GetRemoteServicesAPIStatus() method may be used depending on the version of the LC Management registered profile.
- B) Enable CSIOR (Collect System Inventory on Restart)
 - a. SetAttribute(): Sets attribute to be configured [ReturnValue=0]
 - b. CreateConfigJob(): Creates jobID and applies configuration [ReturnValue=4096]
- C) Call subroutine sub_setEmbNICs_NIC1_NIC2.win to perform the following:
 - a. GetBIOSEnumerations(): Enumerate the DCIM_BIOSEnumeration to obtain the current values of EmbNic attributes
 - b. DeletePendingBIOSConfiguration(): Ensures there is no other pending BIOS configuration
 - c. SetAttribute(): Set parent attribute EmbNic1Nic2 to DisabledOS [ReturnValue=0]
 - d. SetAttribute(): Set child attributes EmbNic1 and EmbNic2 to Disabled [ReturnValue=0]
 - e. CreateBIOSConfigJob(): Creates jobID and applies configuration immediately with reboot job type of 3 [ReturnValue=4096]

NOTE: The following RS Status polling for SSIB task

- f. The Lifecycle Controller remote service must be in a “ready” state before executing any other WSMAN commands. The GetRSStatus() method or the GetRemoteServicesAPIStatus() method may be used depending on the version of the LC Management registered profile.

The GetRSStatus() method must first poll for ‘reloading’ then poll for ‘ready’, while the GetRemoteServicesAPIStatus() can just poll for ‘ready.’

NOTE: The following RS Status polling is for PXE to be set in the boot list during CSIOR

- g. The Lifecycle Controller remote service must be in a “ready” state before executing any other WSMAN commands. The GetRSStatus() method or the GetRemoteServicesAPIStatus() method may be used depending on the version of the LC Management registered profile.

The GetRSStatus() method must first poll for ‘reloading’ then poll for ‘ready’, while the GetRemoteServicesAPIStatus() can just poll for ‘ready.’

- D) Call subroutine sub_setEmbNICs_NIC1_NIC2.win to perform the following:

- a. GetBIOSEnumerations(): Enumerate the DCIM_BIOSEnumeration to obtain the current values of EmbNic attributes
- b. DeletePendingBIOSConfiguration(): Ensures there is no other pending BIOS configuration
- c. SetAttribute(): Set parent attribute EmbNic1Nic2 to Enabled [ReturnValue=0]
- d. SetAttribute(): Set child attributes EmbNic1 and EmbNic2 to EnabledPxe [ReturnValue=0]
- e. CreateBIOSConfigJob(): Creates jobID and applies configuration immediately with reboot job type of 3 [ReturnValue=4096]
NOTE: The following RS Status polling for SSIB task
- f. The Lifecycle Controller remote service must be in a “ready” state before executing any other WSMAN commands. The GetRSStatus() method or the GetRemoteServicesAPIStatus() method may be used depending on the version of the LC Management registered profile.

The GetRSStatus() method must first poll for ‘reloading’ then poll for ‘ready’, while the GetRemoteServicesAPIStatus() can just poll for ‘ready.’

NOTE: The following RS Status polling is for PXE to be set in the boot list during CSIOR

- g. The Lifecycle Controller remote service must be in a “ready” state before executing any other WSMAN commands. The GetRSStatus() method or the GetRemoteServicesAPIStatus() method may be used depending on the version of the LC Management registered profile.

The GetRSStatus() method must first poll for ‘reloading’ then poll for ‘ready’, while the GetRemoteServicesAPIStatus() can just poll for ‘ready.’

- E) Sleep 500 seconds to allow PXE boot to occur. Users would then select applicable PXE boot options before continuing.

Proceed to step F) to disable PXE boot.

- F) Call subroutine sub_setEmbNICs_NIC1_NIC2.win to perform the following:

- a. GetBIOSEnumerations(): Enumerate the DCIM_BIOSEnumeration to obtain the current values of EmbNic attributes
- b. DeletePendingBIOSConfiguration(): Ensures there is no other pending BIOS configuration
- c. SetAttribute(): Set parent attribute EmbNic1Nic2 to Enabled [ReturnValue=0]
- d. SetAttribute(): Set child attributes EmbNic1 and EmbNic2 to Enabled [ReturnValue=0]
- e. CreateBIOSConfigJob(): Creates jobID and applies configuration immediately with reboot job type of 3 [ReturnValue=4096]
NOTE: The following RS Status polling for SSIB task
- f. The GetRSStatus() method must first poll for ‘reloading’ then poll for ‘ready’, while the GetRemoteServicesAPIStatus() can just poll for ‘ready.’

NOTE: The following RS Status polling is for PXE to be set in the boot list during CSIOR

- g. The GetRSStatus() method must first poll for 'reloading' then poll for 'ready', while the GetRemoteServicesAPIStatus() can just poll for 'ready.'

4.14 PXE Boot using embedded NICs (12G only)

This workflow performs a reboot of the host OS into the PXE boot configuration by first setting the *embNic1Nic2* parent attribute and *EmbNicPort1BootProto* (to Pxe) and *EmbNicPort2BootProto* (to None) child attributes. Approximate time for completion on a 12G system is 10-30 minutes depending on the system configuration.

Applies to: LC2+

Prerequisites for script: None

Script: PXEboot_NIC1_NIC2_12G.win

- A) The Lifecycle Controller remote service must be in a "ready" state before executing any other WSMAN commands.

GetRemoteServicesAPIStatus()

- B) Enable CSIOR (Collect System Inventory on Restart)

- a. SetAttribute(): Sets attribute to be configured [ReturnValue=0]
- b. CreateConfigJob(): Creates jobID and applies configuration [ReturnValue=4096]

- C) Call subroutine sub_setEmbNICs_NIC1_NIC2_12G.win to perform the following:

- a. GetBIOSEnumerations(): Enumerate the DCIM_BIOSEnumeration to obtain the current values of EmbNic attributes
- b. DeletePendingBIOSConfiguration(): Ensures there is no other pending BIOS configuration
- c. SetAttribute(): Set parent attribute EmbNic1Nic2 to Enabled [ReturnValue=0]
- d. SetAttribute(): Set child attributes EmbNicPort1BootProto to Pxe and EmbNicPort2BootProto to None [ReturnValue=0]
- e. CreateBIOSConfigJob(): Creates jobID and applies configuration immediately with reboot job type of 3 [ReturnValue=4096]

NOTE: The following polling is for SSIB task

- f. The Lifecycle Controller remote service must be in a "ready" state before executing any other WSMAN commands.

GetRemoteServicesAPIStatus()

- D) Sleep 500 seconds to allow PXE boot to occur. Users would then select applicable PXE boot options before continuing.

Proceed to step E) to disable PXE boot.

- E) Call subroutine sub_setEmbNICs_NIC1_NIC2_12G.win to perform the following:

- a. GetBIOSEnumerations(): Enumerate the DCIM_BIOSEnumeration to obtain the current values of EmbNic attributes
- b. DeletePendingBIOSConfiguration(): Ensures there is no other pending BIOS configuration
- c. SetAttribute(): Set parent attribute EmbNic1Nic2 to Enabled [ReturnValue=0]
- d. SetAttribute(): Set child attributes EmbNicPort1BootProto to None and EmbNicPort2BootProto to None [ReturnValue=0]
- e. CreateBIOSConfigJob(): Creates jobID and applies configuration immediately with reboot job type of 3 [ReturnValue=4096]

NOTE: The following polling is for SSIB task

- f. The Lifecycle Controller remote service must be in a “ready” state before executing any other WSMAN commands.

GetRemoteServicesAPIStatus()

4.15 Set NIC attributes and iSCSI boot using setupjobqueue (11G only)

This workflow sets several NIC attributes, including setup of iSCSI boot, by first setting the required attributes for the operation, and then changing the boot order for the NIC. Approximate time for completion on an 11G system is 15-30 minutes depending on the system configuration.

Applies to: LC1.5.0 & LC1.5.1

Prerequisites for script: Set script variables by editing script

Script: setNICs_iSCSI_boot.win

- A) The Lifecycle Controller remote service must be in a “ready” state before executing any other WSMAN commands. The GetRSStatus() method or the GetRemoteServicesAPIStatus() method may be used depending on the version of the LC Management registered profile.
- B) ENUMERATE the *DCIM_NICView* and *DCIM_SoftwareIdentity* classes to collect information about the system. See section 2.2 for a definition of ENUMERATE .
- C) Enable CSIOR (Collect System Inventory on Restart), if not enabled
 - a. SetAttribute(): Sets attribute to be configured [ReturnValue=0]
 - b. CreateConfigJob(): Creates jobID and applies configuration [ReturnValue=4096]
 - c. Poll jobstatus for Completed: GET the *InstanceID* of from B). See section 2.3 for a definition of GET .

- D) `ENUMERATE` the `DCIM_NICEnumeration`, `DCIM_NICString`, `DCIM_NICInteger`, and `DCIM_BIOSEnumeration` classes to collect information about the system. See section 2.2 for a definition of `ENUMERATE` .
- E) `SetBIOSAttributes()`: Set all the following attributes, if at least one is not set to desired value
- EmbNic1Nic2=Enabled
 - BootMode=BIOS
 - ProcVirtualization= Enabled
 - ErrPrompt=Disabled
 - EmbNic1=Enabled
- F) `CreateBIOSConfigJob()`: Apply step E) with reboot type 3 and `ScheduledStartTime` parameter of `TIME_NOW`, which invokes the operation immediately [Return Value=4096]
- G) Poll jobstatus for Completed: `GET` the `InstanceID` of from F). See section 2.3 for a definition of `GET` .
- NOTE: The following status polling for SSIB task
- F) The Lifecycle Controller remote service must be in a “ready” state before executing any other WSMAN commands. The `GetRSStatus()` method or the `GetRemoteServicesAPIStatus()` method may be used depending on the version of the LC Management registered profile.
- NOTE: The following status polling is for subsequent CSIOR
- G) The Lifecycle Controller remote service must be in a “ready” state before executing any other WSMAN commands. The `GetRSStatus()` method or the `GetRemoteServicesAPIStatus()` method may be used depending on the version of the LC Management registered profile.
- H) `ENUMERATE` the `DCIM_BootSourceSetting` class to collect information about the system. See section 2.2 for a definition of `ENUMERATE` .
- I) `ChangeBootSourceState()`: Loop through boot sources and set their enabled state to zero, except for NIC [Return Value=4096]
- J) `ChangeBootOrderByInstanceID()`: Set the boot order of the NIC to first (`CurrentAssignedSequence = 0`) [Return Value=0]
- K) `SetAttribute()`: Set BIOS attributes EmbNic1 to EnablediScsi [Return Value=0]
- L) `CreateBIOSConfigJob()`: Apply steps J) - L) without reboot, without `UntilTime`, and without `ScheduledStartTime` parameter `TIME_NOW`. [Return Value=4096]
- M) `SetAttribute()`: Set various NIC attributes
- N) `CreateNICConfigJob()`: Apply steps N) without reboot, without `UntilTime`, and without `ScheduledStartTime` parameter `TIME_NOW`. [Return Value=4096]
- O) `CreateRebootJob()`: Pass `RebootJobType` of 3 parameter
- 1 = PowerCycle
 - 2 = Graceful reboot without forced shutdown
 - 3 = Graceful reboot with forced shutdown
- P) `SetupJobQueue()`: Use BIOS JID(L), NIC JID(N), and reboot RID(O) [Return Value=0]

- Q) Poll jobstatus for Completed: `GET` the *InstanceID* of from M). See section 2.3 for a definition of `GET` .
- R) Poll jobstatus for Completed: `GET` the *InstanceID* of from O). See section 2.3 for a definition of `GET` .
- S) The Lifecycle Controller remote service must be in a “ready” state before executing any other WSMAN commands. The `GetRSStatus()` method or the `GetRemoteServicesAPIStatus()` method may be used depending on the version of the LC Management registered profile.

4.16 iSCSI boot using NDC/Broadcom (12G only)

This workflow sets several NIC attributes, including setup of iSCSI boot, by first setting the required attributes for the operation, and then changing the boot order for the NIC. Additional detail is provided as setting up iSCSI boot is complex. Approximate time for completion on a 12G system is 15-30 minutes depending on the system configuration.

NOTE: Additional details of the coding steps shown below, generational differences, and other iSCSI information can be found in Appendix: iSCSI Boot information.

Applies to: LC2+

Prerequisites for script:

- Network Daughter Card (NDC) / Broadcom NIC
- This script will only work using an NIC FQDD of `NIC.Integrated.1-1` or `NIC.Integrated.1-1-1`
- Only works with first port-partition of 12G NDC (script limitation)
- System must be powered off
- Edit script to set desired parameters

Script: `iscsiboot-12gNDC.win`

- A) The Lifecycle Controller remote service must be in a “ready” state before executing any other WSMAN commands.
`GetRemoteServicesAPIStatus()`:
- B) `GetBIOSEnumerations`: `ENUMERATE` the `DCIM_BIOSEnumeration` class to collect information about the system. See section 2.2 for a definition of `ENUMERATE` .
- C) `GetNICViews`: `ENUMERATE` the `DCIM_NICVIEW` class to collect information about the NIC FQDDs. See section 2.2 for a definition of `ENUMERATE` .
- D) `GetBootSourceSettings`: `ENUMERATE` the `DCIM_BootSourceSetting` class to collect information about the NIC FQDDs. See section 2.2 for a definition of `ENUMERATE` .
 - Check whether the FQDD and IPL fields are in the boot order
 - `SetNICAttributes()`: Set the attribute `LegacyBootProto` to the value “iSCSI” and the other desired NIC attributes and values
 - `CreateNICConfigJob()`: Pass `RebootJobType=1`

- E) `GetBootSourceSettings()`: `ENUMERATE` the `DCIM_BootSourceSetting` class to collect information about the NICs. See section 2.2 for a definition of `ENUMERATE` .
 - Check the `CurrentEnabledStatus` to ensure it is enabled
- F) `ChangeBootSourceState()`: Use `InstanceID=IPL EnabledState=1 source=(instanceID from D)`
- G) `ChangeBootOrderByInstanceID()`: Use `InstanceID=IPL source=(instanceID from D)`
- H) `CreateBIOSConfigJob()`: Use `Target=(BIOS FQDD)`
- I) Poll jobstatus for Completed: `GET` the `InstanceID` of from F). See section 2.3 for a definition of `GET` .

4.17 iSCSI boot using QLogic (12G only)

This workflow sets several NIC attributes, including setup of iSCSI boot, by first setting the required attributes for the operation, and then changing the boot order for the NIC. Additional detail is provided as setting up iSCSI boot is complex. Approximate time for completion on a 12G system is 15-30 minutes depending on the system configuration.

NOTE: Additional details of the coding steps shown below, generational differences, and other iSCSI information can be found in Appendix: iSCSI Boot information.

Applies to: LC2+

Prerequisites for script:

- QLogic NIC
- Edit script to set desired parameters
- FQDD must be `NIC.Integrated.1-1-1` or `NIC.Integrated.1-1`

Script: `iscsiboot-12gNDC-qlogic.win`

The four high level steps, which may require four reboots, are the following:

- 1) If the NDC is disabled, 1 job to enable it in bios and reboot
- 2) Now that the card is present, if `iscsi offload on 1-3` is disabled, create a job and reboot to enable it
- 3) Once iSCSI is enabled, configure iSCSI, but it will not show up in the boot order until after reboot
- 4) Once it is in the boot order, move it to the top of the HD list

- A) The Lifecycle Controller remote service must be in a “ready” state before executing any other WSMAN commands.

`GetRemoteServicesAPIStatus()`:

- B) `GetBIOSEnumerations()`: `ENUMERATE` the `DCIM_BIOSEnumeration` class to collect information about the system. See section 2.2 for a definition of `ENUMERATE` .
 - Ensure `AttributeName` of `IntegratedNetwork1` is enabled

- If it is not enabled, enable it as shown below
 - SetBIOSAttributes()
 - AttributeName=IntegratedNetwork1 AttributeValue=Enabled
 - AttributeName=BootMode AttributeValue=Bios
 - CreateBIOSConfigJob()
 - ScheduledStartTime=TIME_NOW RebootJobType=1
 - Poll jobstatus for Completed: GET the InstanceID of from 2).
- C) GetNICViews: ENUMERATE the *DCIM_NICVIEW* class to collect information about the NIC FQDDs. See section 2.2 for a definition of ENUMERATE .
- Check if specified FQDD is present in NICViews, If not, go to NICError
- D) GetBootSourceSettings(): ENUMERATE the *DCIM_BootSourceSetting* class to collect information about the boot sources. See section 2.2 for a definition of ENUMERATE .
- Loop through all boot sources, if boot source is IPL entry, set EnabledState=0 unless HD
- E) ChangeBootSourceState(): Use InstanceID=IPL EnabledState=0 source=(instanceID from D)
- F) GetBootSourceSettings(): ENUMERATE the *DCIM_BootSourceSetting* class to collect information about the boot sources. See section 2.2 for a definition of ENUMERATE .
- Enable the HD boot source
- G) ChangeBootSourceState(): Use InstanceID=IPL EnabledState=1 source=(instanceID from F)
- H) GetBootSourceSettings(): ENUMERATE the *DCIM_BootSourceSetting* class to collect information about the boot sources. See section 2.2 for a definition of ENUMERATE .
- Change NIC boot source
- I) GetBootSourceSettings(): ENUMERATE the *DCIM_BootSourceSetting* class to collect information about the boot sources. See section 2.2 for a definition of ENUMERATE .
- Check NIC boot order
- J) ChangeBootOrderByInstanceID(): Use InstanceID=IPL source=(instanceID from I)
- SetNICAttributes(): Set the attribute LegacyBootProto to the value “iSCSI” and the other desired NIC attributes and values
- K) CreateBIOSConfigJob(): Use Target=(BIOS FQDD)
- ScheduledStartTime=TIME_NOW RebootJobType=1
- L) Poll jobstatus for Completed: GET the InstanceID of from F). See section 2.3 for a definition of GET .

Notes:

- 1) QLogic will not show up in the boot list until it connects to an iSCSI target. So if iSCSI is misconfigured, or the network is down, it does not show up.
- 2) RAID and SATA HDs cannot be disabled in the boot list. Either disable the controller, but then they are not available as secondary disks, or move them down in the HD boot list.
- 3) It is recommended to disable the entire HD list from the boot order until iSCSI is on the top, to prevent it from booting into another HD

4.18 iSCSI boot using Intel (12G only)

This workflow sets several NIC attributes, including setup of iSCSI boot, by first setting the required attributes for the operation, and then changing the boot order for the NIC. Additional detail is provided as setting up iSCSI boot is complex. Approximate time for completion on a 12G system is 15-30 minutes depending on the system configuration.

NOTE: Additional details of the coding steps shown below, generational differences, and other iSCSI information can be found in Appendix: iSCSI Boot information.

Applies to: LC2+

Prerequisites for script:

- Intel NIC
- Edit script to set desired parameters

Script: `iscsiboot-12gHBA-intel.win`

- A) The Lifecycle Controller remote service must be in a “ready” state before executing any other WSMAN commands.
 - `GetRemoteServicesAPIStatus()`
- B) `GetNICViews`: `ENUMERATE` the `DCIM_NICVIEW` class to collect information about the NIC FQDDs. See section 2.2 for a definition of `ENUMERATE`.
 - Check if specified NIC FQDD is present in `NICViews`
- C) `GetNICEnumerations`: `ENUMERATE` the `DCIM_NICEnumeration` class to collect information about the system. See section 2.2 for a definition of `ENUMERATE`.
 - Check if `TcplpViaDHCP=Enabled` and `IscsiViaDHCP=Disabled`
- D) `GetBootSourceSettings`: `ENUMERATE` the `DCIM_BootSourceSetting` class to collect information about the NIC FQDDs. See section 2.2 for a definition of `ENUMERATE`.
 - Loop through all boot sources, if boot source is IPL entry, set `CurrentEnabledStatus=0` unless HD [Steps D)-F)]
- E) `ChangeBootSourceState()`: Use `InstanceID=IPL EnabledState=0 source=(instanceID from C)`

- Set CurrentEnabledStatus=1 for NIC FQDD boot source
- F) GetBootSourceSettings(): ENUMERATE the *DCIM_BootSourceSetting* class to collect information about the NICs. See section 2.2 for a definition of ENUMERATE .
- Check the CurrentEnabledStatus state
- G) Configure iSCSI
- CreateBIOSConfigJob(): Target=(BIOS FQDD)
 - SetNICAttributes(): Target=(NIC FQDD) Set the attribute LegacyBootProto to the value iSCSIPrimary
 - CreateNICConfigJob(): Target=(NIC FQDD)
 - Poll jobstatus for Completed using instanceID from CreateNICConfigJob()
- H) Move iSCSI to the top of the HD Boot List by looping through boot sources
- GetBootSourceSettings()
 - ChangeBootSourceState(): Use InstanceID=IPL EnabledState=1 source=(instanceID from GetBootSourceSettings())
- I) GetBootSourceSettings(): ENUMERATE the *DCIM_BootSourceSetting* class to collect information about the NIC FQDDs. See section 2.2 for a definition of ENUMERATE .
- Loop through boot sources to confirm the NIC FQDD and “BCV” are in an instanceID
- J) Set NIC to first in boot order
- GetBootSourceSettings()
 - ChangeBootOrderByInstanceID(): Use InstanceID=BCV and source=(instanceID from GetBootSourceSettings())
 - CreateBIOSConfigJob(): Use Target=(BIOS FQDD)
 - Poll jobstatus for Completed: GET the *InstanceID* of from BIOS config job

Notes:

- 1) Intel will not show up in the boot list until it connects to an iSCSI target. So if you misconfigure iSCSI or the network is down it does not show up.
- 2) You cannot disable RAID and SATA HDs in the boot list. Either disable the controller, but then they are not available as secondary disks or move them down in the HD boot list.
- 3) It may be a good idea to disable the whole HD list from the boot order until iSCSI is on the top, to prevent it booting into another

HD

4.19 IO Identity

This workflow sets IO Identity NIC attributes by first setting the required attributes for the operation, and then applying the changes immediately using the TIME_NOW parameter. Note that these attributes are read-only on some NIC cards, and read-write on others (i.e. Broadcom 57712). Approximate time for completion on a 12G system is 15-30 minutes depending on the system configuration.

NOTE: These attributes can only be set remotely, not locally. Also, if A/C power is lost, these settings will also be lost.

Applies to: LC1.5.0+

Prerequisites for script:

- Broadcom 57712 hardware or QLogic 8262
- Set FQDD of desired NIC, VirtLscsiMacAddr, and VirtMacAddr by editing the following script

Script: IO_Identity.win

- A) The Lifecycle Controller remote service must be in a “ready” state before executing any other WSMAN commands. The GetRSStatus() method or the GetRemoteServicesAPIStatus() method may be used depending on the version of the LC Management registered profile.
 - B) ENUMERATE the *DCIM_NICString* class to collect information about the NIC’s attributes and FQDD. See section 2.2 for a definition of ENUMERATE .
 - C) SetAttribute(): Set various NIC attributes
 - D) CreateNICConfigJob(): Apply step C) [ReturnValue=4096]
 - E) Poll jobstatus for Completed: GET the InstanceID of from D). See section 2.3 for a definition of GET .
 - F) The Lifecycle Controller remote service must be in a “ready” state before executing any other WSMAN commands. The GetRSStatus() method or the GetRemoteServicesAPIStatus() method may be used depending on the version of the LC Management registered profile.
The GetRSStatus() method must first poll for ‘reloading’ then poll for ‘ready’, while the GetRemoteServicesAPIStatus() can just poll for ‘ready.’
- [Pre-LC2] NOTE:** The following RS Status polling is for CSIOR, assuming its enabled
- G) The Lifecycle Controller remote service must be in a “ready” state before executing any other WSMAN commands. The GetRSStatus() method or the GetRemoteServicesAPIStatus() method may be used depending on the version of the LC Management registered profile.
The GetRSStatus() method must first poll for ‘reloading’ then poll for ‘ready’, while the GetRemoteServicesAPIStatus() can just poll for ‘ready.’

- H) `ENUMERATE` the `DCIM_NICString` class and ensure the attributes were applied correctly. See section 2.2 for a definition of `ENUMERATE` .

4.20 Export LC log

This workflow exports the LC log to either an NFS or CIFS share. Approximate time for completion on an 12G system is 5 minutes depending on the system configuration.

Applies to: LC1.5.0+

Prerequisites for script:

- Set script variables by editing script

Script: ExportLCLog.win

- A) The Lifecycle Controller remote service must be in a “ready” state before executing any other WSMAN commands. The `GetRSStatus()` method or the `GetRemoteServicesAPIStatus()` method may be used depending on the version of the LC Management registered profile.
- B) `ExportLCLlog()`: Invokes the export operation [`ReturnValue=4096`]
- NOTE:** The user must set applicable IP address, username, password, filename, and workgroup of the network share.
- C) Poll jobstatus for Completed: `GET` the `InstanceID` of from D). See section 2.3 for a definition of `GET` .

4.21 FCoE boot using QLogic (12G only)

This workflow sets several NIC attributes, including setup of Fiber Channel over Ethernet (FCoE), by first setting the attributes for the operation and then changing the boot order for the NIC. Approximate time for completion on a 12G system is 20-30 minutes depending on the system configuration.

The four high level steps, which may require 3 reboots, are the following:

- 1) If the NDC is disabled, 1 job to enable it in bios and reboot
- 2) Now that the card is present, if FCoE offload on 1-1-4 is disabled, enable it
Once FCoE is enabled, configure FCoE, but it will not show up in the boot order until after reboot
- 3) Once it is in the boot order, move it to the top of the HD list

Notes:

- 1) QLogic will not show up in the boot list until it connects to an FCoE target. So if you misconfigure FCoE or the network is down it does not show up.
- 2) You cannot disable RAID and SATA HDs in the boot list. Either disable the controller, but then they are not available as secondary disks or move them down in the HD boot list.
- 3) It may be a good idea to disable the whole HD list from the boot order until FCoE is on the top, to prevent it booting into another

HD

- 4) port settings are configured against partition 1 (NIC.Integrated.1-1-1) but the boot target will show up on partition 4 (BCV:BIOS.Setup.1-1#HddSeq#NIC.Integrated.1-1-4)

Applies to: LC2+

Prerequisites for script:

- QLogic NDC
- Set desired script variables by editing script
- FQDD must be NIC.Integrated.1-1-1 (for port setting) and NIC.Integrated.1-1-4 (for boot target setting)

Script: FCoEboot-12gNDC-qlogic.win

- A) The Lifecycle Controller remote service must be in a “ready” state before executing any other WSMAN commands. The GetRSStatus() method or the GetRemoteServicesAPIStatus() method may be used depending on the version of the LC Management registered profile.
1. System should be power off
 2. Clear all unfinished jobs
 3. Clear all pending data
- B) Check NDC is enabled
1. GetBIOSEnumerations(): ENUMERATE the *DCIM_BIOSEnumeration* class to collect information about the system. See section 2.2 for a definition of ENUMERATE.
 2. Ensure AttributeName of IntegratedNetwork1 is enabled
If it is not enabled, enable it as shown below
 - SetBIOSAttributes()
AttributeName=IntegratedNetwork1 AttributeValue=Enabled
AttributeName=BootMode AttributeValue=Bios
 - CreateBIOSConfigJob()
 - ScheduledStartTime=TIME_NOW RebootJobType=1
 - Poll jobstatus for Completed: GET the *InstanceID* of from 2).
- C) CheckConnectFirstFCoETarge(): ENUMERATE the NIC FADD and check if ConnectFirstFCoETarget is eabled, if not, enable ConnectFirstFCoETarget as show below
- Disable all sources
 - Create BIOS job
 - SetNICAttributes()
AttributeName=ConnectFirstFCoETarget AttributeValue=Enabled
 - CreateNICConfigJob with RebootJobType=1
- D) Configure FCoE
1. Disable all sources
 2. Create BIOS job
 3. Set Partition Attributes as follows:

SetNICAttributes() on NIC.Integrated.1-1-4

```
AttributeName=FCoEOffloadMode AttributeValue=Enabled
AttributeName=VirtFIPMacAddr AttributeValue=$VirtFIPMacAddr
AttributeName=VirtWWN AttributeValue=$VirtWWN AttributeName=VirtWWPN
AttributeValue=$VirtWWPN AttributeName=MinBandwidth
AttributeValue=$MinBandwidth AttributeName=MaxBandwidth
AttributeValue=$MaxBandwidth
```

4. CreateNICConfigJob()
5. Set Port Attributes as follows:

```
SetNICAttributes() on NIC.Integrated.1-1-1
AttributeName=FirstFCoEWWPNTarget AttributeValue=$FirstFCoEWWPNTarget
AttributeName=FirstFCoEBootTargetLUN AttributeValue=$FirstFCoEBootTargetLUN
```

6. CreateNICConfigJob() with RebootJobType=1

- E) GetBootSourceSettings(): ENUMERATE the *DCIM_BootSourceSetting* class to collect information about the boot sources. See section 2.2 for a definition of ENUMERATE .
Loop through all boot sources, if boot source is IPL entry, set EnabledState=0 unless HD.
- F) ChangeBootSourceState(): Use InstanceID=IPL EnabledState=0 source=(instanceID from D)
- G) GetBootSourceSettings(): ENUMERATE the *DCIM_BootSourceSetting* class to collect information about the boot sources. See section 2.2 for a definition of ENUMERATE.
- H) Enable the HD boot source
- I) ChangeBootSourceState(): Use InstanceID=IPL EnabledState=1 source=(instanceID from F)
GetBootSourceSettings(): ENUMERATE the *DCIM_BootSourceSetting* class to collect information about the boot sources. See section 2.2 for a definition of ENUMERATE.
Change NIC boot source
- J) GetBootSourceSettings(): ENUMERATE the *DCIM_BootSourceSetting* class to collect information about the boot sources. See section 2.2 for a definition of ENUMERATE .
Check NIC boot order
- K) ChangeBootOrderByInstanceID(): Use InstanceID=IPL source=(instanceID from I)
SetNICAttributes(): Set the attribute LegacyBootProto to the value "FCoE" and the other desired NIC attributes and values
- L) CreateBIOSConfigJob(): Use Target=(BIOS FQDD)
ScheduledStartTime=TIME_NOW RebootJobType=1
- M) Poll jobstatus for Completed: GET the *InstanceID* of from F). See section 2.3 for a definition of GET.

4.22 FCoE boot using Intel (12G only)

This workflow sets several NIC attributes, including setup of Fiber Channel over Ethernet (FCoE), by first setting the attributes for the operation and then changing the boot order for

the NIC. Approximate time for completion on a 12G system is 20-30 minutes depending on the system configuration.

Applies to: LC2+

Prerequisites for script:

- Intel NIC Mezz card
- Set desired script variables by editing script

NOTES:

- Make sure Mezz NIC is enabled
If not enabled, enable it and find NIC FQDD, reboot
- Enable ConnectFirstFCoETarget
Check if ConnectFirstFCoETarget is enabled, if not enable it
Configure FCoE, reboot
- Move FCoE to the top of the HD Boot List

Script: FCoEboot-12g-IntelMezz.win

A) The Lifecycle Controller remote service must be in a “ready” state before executing any other WSMAN commands. GetRemoteServicesAPIStatus():

1. System should be power off
2. Clear all unfinished jobs
3. Clear all pending data

B) Check NIC is enabled

1. GetBIOSEnumerations(): ENUMERATE the *DCIM_BIOSEnumeration* class to collect information about the system. See section 2.2 for a definition of ENUMERATE.
2. Ensure AttributeName of Slot2 is enabled

If it is not enabled, enable it as shown below

SetBIOSAttributes()

- AttributeName= Slot2 AttributeValue=Enabled
- AttributeName=BootMode AttributeValue=Bios
- CreateBIOSConfigJob()
- ScheduledStartTime=TIME_NOW RebootJobType=1
- Poll jobstatus for Completed: GET the *InstanceID* of from 2).

C) CheckConnectFirstFCoETarge(): ENUMERATE the NIC FADD and check if ConnectFirstFCoETarget is eabled, if not, enable ConnectFirstFCoETarget as show below

- SetNICAttributes()
Attribute=LegacyBootProto AttributeValue=FCoE
Attribute=ConnectFirstFCoETarget AttributeValue=Enabled
- Disable all sources
- Create BIOS job
- SetNICAttributes()
Attribute=ConnectFirstFCoETarget AttributeValue=Enabled
- CreateNICConfigJob with RebootJobType=1

D) Configure FCoE

1. Disable all sources
2. Create BIOS job
3. Set Attributes (VLAN etc) as follows
 - SetNICAttributes() on NIC.Mezzanine.2B-1
Attribute=FCoEOffloadMode AttributeValue=Enabled

Attribute=VirtFIPMacAddr AttributeValue=\$VirtFIPMacAddr
Attribute=VirtWWN AttributeValue=\$VirtWWN Attribute=VirtWWPN
AttributeValue=\$VirtWWPN Attribute=MinBandwidth
AttributeValue=\$MinBandwidth Attribute=MaxBandwidth
AttributeValue=\$MaxBandwidth
4. CreateNICConfigJob()
5. Set Attributes (target)as follows
 - SetNICAttributes() on NIC.Mezzanine.2B-1

Attribute=FirstFCoEWWPNTarget AttributeValue=\$FirstFCoEWWPNTarget
Attribute=FirstFCoEBootTargetLUN AttributeValue=\$FirstFCoEBootTargetLUN
6. CreateNICConfigJob() with RebootJobType=1

E) GetBootSourceSettings(): ENUMERATE the *DCIM_BootSourceSetting* class to collect information about the boot sources. See section 2.2 for a definition of ENUMERATE .

Loop through all boot sources, if boot source is IPL entry, set EnabledState=0 unless HD.

- F) `ChangeBootSourceState()`: Use `InstanceID=IPL EnabledState=0` `source=(instanceID from D)`
- G) `GetBootSourceSettings()`: ENUMERATE the `DCIM_BootSourceSetting` class to collect information about the boot sources. See section 2.2 for a definition of ENUMERATE.
- H) Enable the HD boot source
- I) `ChangeBootSourceState()`: Use `InstanceID=IPL EnabledState=1` `source=(instanceID from F)`
`GetBootSourceSettings()`: ENUMERATE the `DCIM_BootSourceSetting` class to collect information about the boot sources. See section 2.2 for a definition of ENUMERATE.

Change NIC boot source
- J) `GetBootSourceSettings()`: ENUMERATE the `DCIM_BootSourceSetting` class to collect information about the boot sources. See section 2.2 for a definition of ENUMERATE .

Check NIC boot order
- K) `ChangeBootOrderByInstanceID()`: Use `InstanceID=IPL` `source=(instanceID from I)`

`SetNICAttributes()`: Set the attribute `LegacyBootProto` to the value “FCoE” and the other desired NIC attributes and values
- L) `CreateBIOSConfigJob()`: Use `Target=(BIOS FQDD)`

`ScheduledStartTime=TIME_NOW` `RebootJobType=1`
- M) Poll jobstatus for Completed: GET the `InstanceID` of from F). See section 2.3 for a definition of GET.

4.23 FCoE boot using Broadcom (12G only)

This workflow sets several NIC attributes, including setup of Fiber Channel over Ethernet (FCoE), by first setting the attributes for the operation and then changing the boot order for the NIC. Approximate time for completion on a 12G system is 20-30 minutes depending on the system configuration.

Applies to: LC2+

Prerequisites for script:

- **Broadcom Mezz card using slot1**
- **Set desired script variables by editing script**

Script: FCoEboot-12g-Broadcom.win

The four high level steps, which may require 3 reboots, are the follows:

- 1) If the NIC is disabled, 1 job to enable it in bios and reboot
 - 2) If partition disabled, 1 job to enable partition and reboot
 - 3) Once both NIC card and partition are enabled, set the FCoE related NIC attributes and reboot
 - 4) After that, the NIC will show up in the IPL list, enable it.
- A) Check the NIC is enabled
1. GetBIOSEnumerations(): ENUMERATE the *DCIM_BIOSEnumeration* class to collect information about the system.
 2. Ensure AttributeName of \$nicAttributeName is enabled
If it is not enabled, enable it as shown below
 - SetBIOSAttributes()
AttributeName=\$nicAttributeName AttributeValue=Enabled
AttributeName=BootMode AttributeValue=Bios
 - CreateBIOSConfigJob()
 - ScheduledStartTime=TIME_NOW RebootJobType=1
 - Poll jobstatus for Completed
- B) Check partition is enabled, if not enable it as follows
AttributeName=NicPartitioning AttributeValue=Enabled
- C) Configure FCoE
1. Disable all sources
 2. Create BIOS job
 3. Set the following attributes
LegacyBootProto=FCoE
ConnectFirstFCoETarget=Enabled
FCoEOffloadMode=Enabled
FCoETgtBoot=Enabled
VirtWWPN=your WWPN address
FirstFCoEWWPNTarget=your FirstFCoEWWPNTarget address
FirstFCoEBootTargetLUN=your FirstFCoEBootTargetLUN value
- D) GetBootSourceSettings(): ENUMERATE the *DCIM_BootSourceSetting* class to collect information about the boot sources.
- E) Loop through all boot sources, until find the NIC, then enable the NIC boot source

4.24 IO Identity for QLogic (12G only)

This workflow sets IO Identity, which are the following: virtual Mac address, virtual iSCSI Mac address, virtual FIP Mac address, virtual WWN, and virtual WWPN. This workflow is for Qlogic cards only.

This script has been tested on Qlogic Mezz card, slot 2 with the following setting. Different cards or different slots require modifications to the script.

- \$nic=NIC.Mezzanine.2B-1-1
- \$nic2=NIC.Mezzanine.2B-1-2
- \$nic3=NIC.Mezzanine.2B-1-3
- \$nic4=NIC.Mezzanine.2B-1-4
- \$nicAttributeName=Slot2

The script is an example for set IO identity for the following card setting:

- Partition 1: NIC
- Partition 3: iSCSI
- Partition 4: FCoE

Applies to: LC2+

Prerequisites for script:

- QLogic card
- Set desired script variables by editing script

Script: IO_IdentityQlogic.win

A) The Lifecycle Controller remote service must be in a “ready” state before executing any other WSMAN commands.

GetRemoteServicesAPIStatus():

B) Check NIC is enabled

1. GetBIOSEnumerations(): ENUMERATE the *DCIM_BIOSEnumeration* class to collect information about the system.

2. Ensure AttributeName of \$nicAttributeName is enabled
If not enabled, enable it as shown below

- SetBIOSAttributes()
AttributeName=\$nicAttributeName AttributeValue=Enabled
AttributeName=BootMode AttributeValue=Bios
- CreateBIOSConfigJob()
- ScheduledStartTime=TIME_NOW RebootJobType=1
- Poll job status for Completed.

C) Disable the FlexAddress

- SetLCAttributes AttributeName=VirtualAddressManagement AttributeValue=Console

D) Set IO Identity

- SetNICAttributes()
 - For partition 1: AttributeName=VirtMacAddr
AttributeValue=\$VirtMacAddr_value
 - For partition 3: AttributeName=VirtIscsiMacAddr
AttributeValue=\$VirtIscsiMacAddr_value
 - For partition 4: AttributeName=VirtFIPMacAddr
AttributeValue=\$VirtFIPMacAddr_value
AttributeName=VirtWWN AttributeValue=\$VirtWWN_value
AttributeName=VirtWWPN AttributeValue=\$VirtWWPN_value
- CreateNICConfigJob() for
 - Partition 1
 - Partition 3
 - Partition 4
 - Then Reboot
- Poll job status for completion using InstanceID from CreateNICConfigJob()

4.25 IO Identity for Broadcom (12G only)

This workflow sets IO Identity for Broadcom card only.

The script is an example for setting IO Identity for the following set:

- Partition Disabled

Applies to: LC2+

Prerequisites for script:

- Broadcom card
- Set desired script variables by editing script

Script: IO_IdentityBroadcom.win

- A) The Lifecycle Controller remote service must be in a “ready” state before executing any other WSMAN commands.

GetRemoteServicesAPIStatus():

B) Check NIC is enabled

1. GetBIOSEnumerations(): ENUMERATE the *DCIM_BIOSEnumeration* class to collect information about the system.
2. Ensure the NIC is enabled

If not enabled, enable it as shown below

- SetBIOSAttributes() Target = (BIOS FQDD)
- CreateBIOSConfigJob() Target = (BIOS FQDD)
- ScheduledStartTime=TIME_NOW RebootJobType=1
- Poll job status for Completed

C) Disable the FlexAddress

- SetLCAttributes AttributeName=VirtualAddressManagement
AttributeValue=Console

D) Set IO Identity

- SetNICAttributes() Target = (NIC FQDD)
- CreateNICConfigJob() Target = (NIC FQDD)
- Poll job status for completion using instanceID from CreateNICConfigJob()

4.26 IO Identity for Intel (12G only)

This workflow sets IO Identity for Intel cards only. The script is an example for setting IO Identity for the following:

- Port 1
- NIC
- FCoE

Applies to: LC2+

Prerequisites for script:

- Intel card
- Set desired script variables by editing script
- Intel cards have no partitions

Script: IO_IdentityIntel.win

- A) The Lifecycle Controller remote service must be in a “ready” state before executing any other WSMAN commands.

GetRemoteServicesAPIStatus():

- B) Check NIC is enabled

1. GetBIOSEnumerations(): ENUMERATE the *DCIM_BIOSEnumeration* class to collect information about the system.
2. Ensure the NIC is enabled

If not enabled, enable it as shown below

- SetBIOSAttributes() Target = (BIOS FQDD)
- CreateBIOSConfigJob()Target = (BIOS FQDD)
- ScheduledStartTime=TIME_NOW RebootJobType=1
- Poll job status for Completed.

- C) Disable the FlexAddress

- SetLCAttributes AttributeName=VirtualAddressManagement AttributeValue=Console

- D) Set IO Identity

- SetNICAttributes() Target = (NIC FQDD) AttributeName= VirtMacAddr/ VirtFIPMacAddr/ VirtWWN/VirtWWPN
- CreateNICConfigJob() Target = (NIC FQDD) RebootJobType=1
- Poll job status for completion using instanceID from CreateNICConfigJob()

4.27 Export System Configuration (12G only)

This method is used to export the system configuration from the Lifecycle Controller to a file on a remote share.

Applies to: LC2.1+

Prerequisites for script:

- Set script variables by editing script

Script: ExportSystemConfiguration.win

- A) The Lifecycle Controller remote service must be in a “ready” state before executing any other WSMAN commands. The GetRemoteServicesAPIStatus() method may be used depending on the version of the LC Management registered profile.
- B) ExportSystemConfiguration(): Invokes the export operation [ReturnValue=4096]

NOTE: The user must set applicable IP address, username, password, and filename of the network share.

- C) Poll jobstatus for Completed: GET the *InstanceID* of from B). See section 2.3 for a definition of GET .

4.28 Import System Configuration (12G only)

This method is used to import the system configuration from the Lifecycle Controller to a file on a remote share.

Applies to: LC2.1+

Prerequisites for script:

- Set script variables by editing script

Script: ImportSystemConfiguration.win

- A) The Lifecycle Controller remote service must be in a “ready” state before executing any other WSMAN commands. The GetRemoteServicesAPIStatus() method may be used depending on the version of the LC Management registered profile.

B) ImportSystemConfiguration(): Invokes the import operation [ReturnValue=4096]

NOTE: The user must set applicable IP address, username, password, and filename of the network share.

C) Poll jobstatus for Completed: GET the InstanceID of from B). See section 2.3 for a definition of GET .

4.29 Configurable Boot to network ISO

The ConfigurableBootToNetworkISO() method exposes an ISO Image present on a network share as a CDROM device to the host server for a specified exposure duration interval or by default for 18 hrs. Upon the successful execution, based on the ResetType parameter, the host system shall either immediately cold boot or warm boot. Upon this reset, the system shall then boot to the ISO Image. If ResetType specifies no immediate reboot, then upon the next host system reset, the system shall boot to the ISO Image. Furthermore, if immediate reset is not specified, then the system should be rebooted before the exposure duration interval expires, otherwise the system shall fail to boot to the ISO Image.

The workflow first removes any existing driver packs or existing attached OS, then gets available OS drivers, unpacks the desired set of drivers, and boots from an image on a network share. Approximate time for completion on a 12G system is 20-40 minutes depending on the size of the driver pack that will be unpacked and the speed of the network to boot image.

The workflow differs from the 4.3 Boot to Network ISO in that the reboot can be configured for the following:

- Warm boot
- Cold boot
- No reset

Applies to: LC2.1+

Prerequisites for script:

- Place applicable ISO image in applicable network share
- Set script variables by editing script

Script: BootToNetworkISO.win

A) The Lifecycle Controller remote service must be in a “ready” state before executing any other WSMAN commands. The GetRSStatus() method or the GetRemoteServicesAPIStatus() method may be used depending on the version of the LC Management registered profile.

NOTE: GetRemoteServicesAPIStatus() will return “not ready” if drivers or an ISO is already attached.

- B) `DetachDrivers()`: Ensures any drivers are detached.
- C) `DetachISOImage()`: Ensures all images are detached.
- D) `GetDriverPackInfo()`: Displays available OS drivers. This is only required for end to end OS deployment.
- E) `UnpackAndAttach()`: Unpacks and attaches desired driver pack. The resulting concrete job is invoked immediately. This is only required for end to end OS deployment.
- F) Poll concrete job until 'Success'.
- G) `BootToNetworkISO()`: The resulting concrete job may be invoked immediately depending on the reset type.
- H) Poll concrete job until 'Success'.

5 Base Metrics Profile Use Cases

5.1 Discovery of Base Metrics profile support

Use the following procedure below to confirm the existence of Base Metrics profile support.

NOTE: Prior to LC2.0.0, this profile resided as a CIM profile, not LC profile.

Applies to: LC1.5.1+

Prerequisites for script: none

Script: `GetBaseMetricsProfile.win`

- A) The Lifecycle Controller remote service must be in a "ready" state before executing any other WSMAN commands. The `GetRSStatus()` method or the `GetRemoteServicesAPIStatus()` method may be used depending on the version of the LC Management registered profile.
- B) `ENUMERATE` the applicable class to view all registered profiles. See section 2.2 for a definition of `ENUMERATE` .
`[LC1.5.0/LC1.5.1]GetCIMRegisteredProfiles():`
`[LC2.0.0]GetLCRegisteredProfiles():`
- C) Search for "RegisteredName= Role Based Authorization" and note its `instanceID` to use in step D)
- D) `GET` the applicable instance using the `InstanceID` from C). See Section 2.3 for a definition of `GET` .
`[LC1.5.0/LC1.5.1] GetCIMRegisteredProfile():`
`[LC2.0.0] GetLCRegisteredProfile():`

Results for the *InstanceID* of *DCIM:BaseMetrics:1.0.0* shown below. If no instance is returned, the profile is not supported.

```
DCIM_LCRegisteredProfile
  AdvertiseTypeDescriptions = WS-Identify
  AdvertiseTypeDescriptions = Interop Namespace
  AdvertiseTypes = 1
  AdvertiseTypes = 1
  InstanceID = DCIM:BaseMetrics:1.0.0
  OtherRegisteredOrganization = DCIM
  ProfileRequireLicense = Power Monitoring
  ProfileRequireLicenseStatus = LICENSED
  RegisteredName = Base Metrics
  RegisteredOrganization = 1
  RegisteredVersion = 1.0.0
```

6 BIOS and Boot Management Profile Use Cases

6.1 Discovery of BIOS and boot profile support

Use the following procedure below to confirm the existence of BIOS and boot profile support.

Applies to: LC1.5.0+

Prerequisites for script: none

Script: GetBIOSandBootProfile.win

- A) The Lifecycle Controller remote service must be in a “ready” state before executing any other WSMAN commands. The GetRSStatus() method or the GetRemoteServicesAPIStatus() method may be used depending on the version of the LC Management registered profile.
- B) GetLCRegisteredProfiles(): ENUMERATE the *DCIM_LCRegisteredProfile* class to view all registered profiles. See section 2.2 for a definition of ENUMERATE .
- C) Search for “RegisteredName= BIOS and Boot Management” and note its instanceID to use in step D)
- D) GetLCRegisteredProfile(): GET the *DCIM_LCRegisteredProfile* instance using the *InstanceID* from C). See Section 2.3 for a definition of GET .

Results for the *InstanceID* of *DCIM:BIOSandBootManagement:1.0.0* shown below. If no instance is returned, the profile is not supported.

```
DCIM_LCRegisteredProfile
  AdvertiseTypeDescriptions = WS-Identify
  AdvertiseTypeDescriptions = Interop Namespace
  AdvertiseTypes = 1
  AdvertiseTypes = 1
```

InstanceID = DCIM:BIOSandBootManagement:1.0.0
OtherRegisteredOrganization = DCIM
ProfileRequireLicense = Remote Firmware Configuration
ProfileRequireLicenseStatus = LICENSED
RegisteredName = BIOS and Boot Management
RegisteredOrganization = 1
RegisteredVersion = 1.2.0

6.2 List all BIOS attributes

Use the following procedure below to view all available instances of the *DCIM_BIOSEnumeration* class, *DCIM_BIOSInteger* class, and *DCIM_BIOSString* classes in the system.

Applies to: LC1.5.0+

Prerequisites for script: none

Script: GetAllBIOSAttributes.win

- A) The Lifecycle Controller remote service must be in a “ready” state before executing any other WSMAN commands. The `GetRSStatus()` method or the `GetRemoteServicesAPIStatus()` method may be used depending on the version of the LC Management registered profile.
- B) `ENUMERATE` the following classes to view all instances. See section 2.2 for a definition of `ENUMERATE` .

`GetBIOSEnumerations()`: Returns instance information from *DCIM_BIOSEnumeration* class

`GetBIOSIntegers()`: Returns instance information from *DCIM_BIOSInteger* class

`GetBIOSStrings()`: Returns instance information from *DCIM_BIOSString* class

The instance information of all available BIOS attributes will be returned.

6.3 Delete pending BIOS configuration

Use the following procedure below to delete pending BIOS configurations/values set by the `setAttribute(s)` method.

Applies to: LC1.5.0+

Prerequisites for script: none

Script: DeletePendingBIOSConfiguration.win

- A) The Lifecycle Controller remote service must be in a “ready” state before executing any other WSMAN commands. The `GetRSStatus()` method or the `GetRemoteServicesAPIStatus()` method may be used depending on the version of the LC Management registered profile.
- B) `GetBIOSEnumerations ()`: `ENUMERATE` the *DCIM_BIOSEnumeration* class to view all available BIOS FQDDs. See section 2.2 for a definition of `ENUMERATE` .

- C) `DeletePendingBIOSConfiguration()`: Deletes the pending BIOS configuration, using a target FQDD such as `BIOS.Setup.1-1`.

A return message of “No pending data present to delete” indicates that there is no pending BIOS configuration to delete for the respective FQDD.

6.4 Inventory of boot configurations in system

Use the following procedure below to view all available instances of the `DCIM_BootConfigSetting` class.

Applies to: LC1.5.0+

Prerequisites for script: none

Script: `GetBootConfigurations.win`

- A) The Lifecycle Controller remote service must be in a “ready” state before executing any other WSMAN commands. The `GetRSStatus()` method or the `GetRemoteServicesAPIStatus()` method may be used depending on the version of the LC Management registered profile.
- B) `GetBootConfigSettings()`: `ENUMERATE` the `DCIM_BootConfigSetting` class to view all instances. See section 2.2 for a definition of `ENUMERATE` .

The instance information of all available boot configurations will be returned.

6.5 Get the first boot configuration’s information

Use the following procedure to get a single boot configuration instance. The URI for getting particular instance information is deterministic (i.e the `InstanceID` will be unique for each instance).

Applies to: LC1.5.0+

Prerequisites for script:

- Set desired `instanceID` by editing script (default is `IPL`)

Script: `GetBootConfiguration.win`

- A) The Lifecycle Controller remote service must be in a “ready” state before executing any other WSMAN commands. The `GetRSStatus()` method or the `GetRemoteServicesAPIStatus()` method may be used depending on the version of the LC Management registered profile.
- B) `GetBootConfigSetting()`: `GET` the `DCIM_BootConfigSetting` instance using the `InstanceID=IPL`. See Section 2.3 for a definition of `GET` .

The instance of `DCIM_BootConfigSetting` that contains the information on the first boot configuration will be returned

6.6 Inventory of boot sources in system

Use the following procedure below to view all available instances of the *DCIM_BootSourceSetting* class.

Applies to: LC1.5.0+

Prerequisites for script: none

Script: GetBootSources.win

- A) The Lifecycle Controller remote service must be in a “ready” state before executing any other WSMAN commands. The GetRSStatus() method or the GetRemoteServicesAPIStatus() method may be used depending on the version of the LC Management registered profile.
- B) GetBootSourceSettings(): ENUMERATE the *DCIM_BootSourceSetting* class to view all instances. See section 2.2 for a definition of ENUMERATE .

The instance information of all available boot sources will be returned.

6.7 Changing boot order by instance

See Section “4.5: Set hard drive to first in boot order” for a comprehensive example.

6.8 Enable or disable boot source

This workflow can enable[1] (or disable[0]) the hard drive(c:). If the BootMode is set to UEFI, it will change it to BIOS. Following completion of the reboot, the hard drive will be enabled (or disabled). Approximate time for completion that one can expect to encounter on an 11G system is about 15-25 minutes, depending on whether an additional reboot is needed to set the BootMode parameter.

Applies to: LC1.5.0+

Prerequisites for script:

- Set the desired boot source state to enable(1) or disable(0)

Script: EnableBootSource.win

- A) The Lifecycle Controller remote service must be in a “ready” state before executing any other WSMAN commands. The GetRSStatus() method or the GetRemoteServicesAPIStatus() method may be used depending on the version of the LC Management registered profile.
- B) Change BootMode to BIOS, if current value is UEFI
 - a. SetAttribute(): Sets attribute to be configured [ReturnValue=0]
 - b. CreateConfigJob(): Creates jobID and applies configuration [ReturnValue=4096]
- C) GetBootConfigSettings(): ENUMERATE the *DCIM_BootConfigSetting* class to identify the *ElementName* field containing *BootSeq* and corresponding *InstanceID* (IPL or UEFI). See section 2.2 for a definition of ENUMERATE .

ElementName = Hard drive C: BootSeq

- D) **GetBootSourceSettings():** ENUMERATE the *DCIM_BootSourceSetting* class. See section 2.2 for a definition of ENUMERATE .
- a. The CurrentEnabledStatus attribute defines whether the boot source is enabled or disabled
 - b. If the CurrentEnabledStatus is desired value, skip to the end
- E) **ChangeBootSourceState():** using instanceID = IPL and EnabledState=1 [ReturnValue=0]
- F) **Poll jobstatus for Completed:** GET the *InstanceID* of from E). See section 2.3 for a definition of GET .
- I) The Lifecycle Controller remote service must be in a “ready” state before executing any other WSMAN commands. The GetRSStatus() method or the GetRemoteServicesAPIStatus() method may be used depending on the version of the LC Management registered profile.
- The GetRSStatus() method must first poll for ‘reloading’ then poll for ‘ready’, while the GetRemoteServicesAPIStatus() can just poll for ‘ready.’
- G) ENUMERATE the *DCIM_BootSourceSetting* class. See section 2.2 for a definition of ENUMERATE .
- The CurrentEnabledStatus of the “Hard drive C” should be 1 for enable (or 0 for disable)

6.9 One time boot

This workflow sets a one-time boot for vFlash, IPL, or UEFI. This example uses IPL. Approximate time for completion that one can expect to encounter is about 15-25 minutes.

Applies to: LC1.5.0+

Prerequisites for script:

- none

Script: OneTimeBoot.win

- A) The Lifecycle Controller remote service must be in a “ready” state before executing any other WSMAN commands. The GetRSStatus() method or the GetRemoteServicesAPIStatus() method may be used depending on the version of the LC Management registered profile.
- B) **GetBootConfigSettings():** ENUMERATE the *DCIM_BootConfigSetting* class to identify the *ElementName* field containing *BootSeq* and corresponding *InstanceID* (IPL or UEFI).
- ElementName = Hard drive C: BootSeq
- C) **GetBootSourceSettings():** ENUMERATE the *DCIM_BootSourceSetting* class and identify the desired one time boot source: vFlash, IPL, or UEFI
- D) **ChangeBootOrderByInstanceID():** using instanceID = OneTime and Source=instanceID from C)
- E) **GetBootConfigSettings():** ENUMERATE the *DCIM_BootConfigSetting* class.

- The *OneTime* entry should have an *IsNext* value of 3, which means “Is Next for Single Use”

F) `GetBootSourceSettings()`: `ENUMERATE` the *DCIM_BootSourceSetting* class.

- Verify that an additional entry for that *DCIM_BootSourceSetting* appears with an *InstanceID* prefixed with “OneTime:”, such as `InstanceID = OneTime:IPL:HardDisk.List.1-1:c9203080df84781e2ca3d512883dee6f`.
- After the reboot, the boot list reverts to the original boot list.

The job will be marked ‘Completed’ after the successful one time boot to the device.

7 CPU Profile Use Cases

7.1 Discovery of CPU profile support

Use the following procedure below to confirm the existence of CPU profile support.

Applies to: LC1.5.0+

Prerequisites for script: none

Script: `GetCPUProfile.win`

- A) The Lifecycle Controller remote service must be in a “ready” state before executing any other WSMAN commands. The `GetRSStatus()` method or the `GetRemoteServicesAPIStatus()` method may be used depending on the version of the LC Management registered profile.
- B) `GetLCRegisteredProfiles()`: `ENUMERATE` the *DCIM_LCRegisteredProfile* class to view all registered profiles. See section 2.2 for a definition of `ENUMERATE`.
- C) Search for “RegisteredName=CPU” and note its `instanceID` to use in step D)
- D) `GetLCRegisteredProfile()`: `GET` the *DCIM_LCRegisteredProfile* instance using the *InstanceID* from C). See Section 2.3 for a definition of `GET`.

Results for the *InstanceID* of `DCIM:CPU:1.0.0` shown below. If no instance is returned, the profile is not supported.

```
DCIM_LCRegisteredProfile
  AdvertiseTypeDescriptions = WS-Identify, Interop Namespace
  AdvertiseTypes = 1, 1
  InstanceID = DCIM:CPU:1.0.0
  OtherRegisteredOrganization = DCIM
  ProfileRequireLicense = Remote Inventory
  ProfileRequireLicenseStatus = LICENSED
  RegisteredName = CPU
  RegisteredOrganization = 1
  RegisteredVersion = 1.0.0
```

7.2 Inventory of CPUs in system

Use the following procedure below to list the inventory of all CPUs in the system.

Applies to: LC1.5.0+

Prerequisites for script: none

Script: GetCPUViews.win

- A) The Lifecycle Controller remote service must be in a “ready” state before executing any other WSMAN commands. The GetRSStatus() method or the GetRemoteServicesAPIStatus() method may be used depending on the version of the LC Management registered profile.
- B) GetCPUViews(): ENUMERATE the *DCIM_CPUView* class to view all instances. See section 2.2 for a definition of ENUMERATE .
- The instance information of all available CPUs will be returned.

7.3 Get the first CPU’s information

Use the following procedure to get a single CPU instance. The URI for getting particular instance information is deterministic (i.e the *InstanceID* will be unique for each instance).

Applies to: LC1.5.0+

Prerequisites for script:

- Set desired instanceID by editing script

Script: GetCPUView.win

- A) The Lifecycle Controller remote service must be in a “ready” state before executing any other WSMAN commands. The GetRSStatus() method or the GetRemoteServicesAPIStatus() method may be used depending on the version of the LC Management registered profile.
- B) GetCPUView(): GET the *DCIM_CPUView* instance using the *InstanceID=CPU.Socket.1*. See Section 2.3 for a definition of GET .
- The instance of *DCIM_CPUView* that contains the information on the first CPU will be returned.

8 Event Filter Profile Use Cases

8.1 Discovery of Event Filter profile support

Use the following procedure below to confirm the existence of Event Filter profile support. This profile is currently not supported prior to LC2.

Applies to: LC2+

Prerequisites for script: none

Script: GetEventFilterProfile.win

- A) The Lifecycle Controller remote service must be in a “ready” state before executing any other WSMAN commands.

GetRemoteServicesAPIStatus():

- B) GetLCRegisteredProfiles(): ENUMERATE the *DCIM_LCRegisteredProfile* class to view all registered profiles. See section 2.2 for a definition of ENUMERATE .
- C) Search for “RegisteredName=Event Filter” and note its InstanceID to use in step D)
- D) GetLCRegisteredProfile(): GET the *DCIM_LCRegisteredProfile* instance using the *InstanceID* from C). See Section 2.3 for a definition of GET .

Results for the *InstanceID* of DCIM:EventFilter:1.0.0 shown below. If no instance is returned, the profile is not supported.

```
DCIM_LCRegisteredProfile
  AdvertiseTypeDescriptions = WS-Identify
  AdvertiseTypeDescriptions = Interop Namespace
  AdvertiseTypes = 1
  AdvertiseTypes = 1
  InstanceID = DCIM:EventFilter:1.0.0
  OtherRegisteredOrganization = DCIM
  ProfileRequireLicense = Remote Firmware Configuration
  ProfileRequireLicenseStatus = LICENSED
  RegisteredName = Event Filter
  RegisteredOrganization = 1
  RegisteredVersion = 1.0.0
```

8.2 Get event filter configuration service views

Enumerate the *DCIM_EFConfigurationService* class to view all available instances of the class.

Applies to: LC2+

Prerequisites for script: none

Script: GetEFConfigurationServiceViews.win

- A) The Lifecycle Controller remote service must be in a “ready” state before executing any other WSMAN commands.

GetRemoteServicesAPIStatus():

- B) GetEFConfigurationServiceViews(): ENUMERATE the *DCIM_EFConfigurationService* class to view all instances. See section 2.2 for a definition of ENUMERATE .

The instance information will be returned.

8.3 Get event filter views

Enumerate the *DCIM_EventFilter* class to view all available instances of the class.

Applies to: LC2+

Prerequisites for script: none

Script: GetEventFilterViews.win

- A) The Lifecycle Controller remote service must be in a “ready” state before executing any other WSMAN commands.

GetRemoteServicesAPIStatus():

- B) GetEventFilters(): ENUMERATE the *DCIM_EventFilter* class to view all instances. See section 2.2 for a definition of ENUMERATE .

All available instance information will be returned.

8.4 Get single event filter’s information

Use the following procedure to get a single Event Filter instance. The URI for getting particular instance information is deterministic (i.e the *InstanceID* will be unique for each instance).

Applies to: LC2+

Prerequisites for script:

- Set desired instanceID by editing script

Script: GetEventFilterView.win

- A) The Lifecycle Controller remote service must be in a “ready” state before executing any other WSMAN commands.

GetRemoteServicesAPIStatus():

- B) GetEventFilterView(): GET the *DCIM_EventFilter* instance. See Section 2.3 for a definition of GET .

The desired instance information will be returned.

8.5 Set event filters by category

This workflow is used to set the action and notifications for all the event filters that belong to a particular category, subcategory and severity.

Applies to: LC2+

Prerequisites for script: Set variables by editing script

Script: SetEventFilterByCategory.win

- A) The Lifecycle Controller remote service must be in a “ready” state before executing any other WSMAN commands.

GetRemoteServicesAPIStatus():

- B) SetEventFilterByCategory(): Sets the action and notifications for the event filters

8.6 Set event filters by InstanceID

This workflow is used to set the action and notifications for all the event filters that belong to a particular set of InstanceIDs.

Applies to: LC2+

Prerequisites for script: Set variables by editing script

Script: SetEventFilterByInstanceIDs.win

A) The Lifecycle Controller remote service must be in a “ready” state before executing any other WSMAN commands.

GetRemoteServicesAPIStatus():

B) GetEventFilters(): `ENUMERATE` the *DCIM_EventFilter* class to view all available instances to use in C). See section 2.2 for a definition of `ENUMERATE` .

C) SetEventFilterByInstanceIDs(): Sets the action and notifications for the event filters

9 iDRAC Card Profile Use Cases

9.1 Discovery of iDRAC Card profile support

Use the following procedure below to confirm the existence of iDRAC Card profile support.

Applies to: LC1.5.0+

Prerequisites for script: none

Script: GetiDRACCardProfile.win

A) The Lifecycle Controller remote service must be in a “ready” state before executing any other WSMAN commands. The `GetRSStatus()` method or the `GetRemoteServicesAPIStatus()` method may be used depending on the version of the LC Management registered profile.

B) GetLCRegisteredProfiles(): `ENUMERATE` the *DCIM_LCRegisteredProfile* class to view all registered profiles. See section 2.2 for a definition of `ENUMERATE` .

C) Search for “RegisteredName=iDRAC Card” and note its instanceID to use in step D)

D) GetLCRegisteredProfile(): `GET` the *DCIM_LCRegisteredProfile* instance using the *InstanceID* from C). See Section 2.3 for a definition of `GET` .

Results for the *InstanceID* of *DCIM:iDRACCard:1.0.0* shown below. If no instance is returned, the profile is not supported.

```
DCIM_LCRegisteredProfile
  AdvertiseTypeDescriptions = WS-Identify
  AdvertiseTypeDescriptions = Interop Namespace
  AdvertiseTypes = 1
  AdvertiseTypes = 1
  InstanceID = DCIM:iDRACCard:1.0.0
  OtherRegisteredOrganization = DCIM
  ProfileRequireLicense = Remote Firmware Configuration
```

ProfileRequireLicense = Remote Inventory
ProfileRequireLicense = Virtual Console
ProfileRequireLicense = Virtual Media
ProfileRequireLicense = Two-Factor Authentication
ProfileRequireLicense = Directory Services
ProfileRequireLicense = IPv6
ProfileRequireLicense = Dynamic DNS
ProfileRequireLicenseStatus = LICENSED
ProfileRequireLicenseStatus = LICENSED
ProfileRequireLicenseStatus = LICENSED
ProfileRequireLicenseStatus = LICENSED
ProfileRequireLicenseStatus = LICENSED
ProfileRequireLicenseStatus = LICENSED
ProfileRequireLicenseStatus = LICENSED
ProfileRequireLicenseStatus = LICENSED
RegisteredName = iDRAC Card
RegisteredOrganization = 1
RegisteredVersion = 1.2.0

9.2 Get all iDRAC card attributes

Use the following procedure below to list all of the attributes from all of the iDRAC Card class in the system.

Applies to: LC1.5.0+

Prerequisites for script: none

Script: GetAlliDRACCardAttributes.win

- A) The Lifecycle Controller remote service must be in a “ready” state before executing any other WSMAN commands. The GetRSStatus() method or the GetRemoteServicesAPIStatus() method may be used depending on the version of the LC Management registered profile.
- B) GetiDRACCardAttributes(): ENUMERATE the *DCIM_iDRACCardAttribute* class to view all attributes. See section 2.2 for a definition of ENUMERATE .

9.3 Inventory of iDRAC cards in system

Use the following procedure below to list the inventory of all iDRAC Cards in the system.

Applies to: LC1.5.0+

Prerequisites for script: none

Script: GetiDRACCardViews.win

- A) The Lifecycle Controller remote service must be in a “ready” state before executing any other WSMAN commands. The GetRSStatus() method or the GetRemoteServicesAPIStatus() method may be used depending on the version of the LC Management registered profile.
- B) GetiDRACCardViews(): ENUMERATE the *DCIM_iDRACCardView* class to view all instances. See section 2.2 for a definition of ENUMERATE .

The instance information of all available iDRAC cards will be returned.

9.4 Get the first iDRAC card's information

Use the following procedure to get a single iDRAC instance. The URI for getting particular instance information is deterministic (i.e the *InstanceID* will be unique for each instance).

Applies to: LC1.5.0+

Prerequisites for script:

- Set desired instanceID by editing script

Script: GetiDRACCardView.win

- A) The Lifecycle Controller remote service must be in a “ready” state before executing any other WSMAN commands. The GetRSStatus() method or the GetRemoteServicesAPIStatus() method may be used depending on the version of the LC Management registered profile.
- B) GetiDRACCardView(): GET the *DCIM_iDRACCardView* instance using the *InstanceID=iDRAC.Embedded.1*. See Section 2.3 for a definition of GET .

The instance of *DCIM_iDRACCardView* that contains the information on the first iDRAC card will be returned.

9.5 Set/apply iDRAC card attribute(s) immediately

Use the following procedure to set a iDRAC attributes(s) immediately using the *ApplyAttributes* method. It is not necessary to invoke the *CreateTargetConfigJob* method as with the *SetAttributes* method.

Applies to: LC1.5.0+

Prerequisites for script: Set desired values by editing script

Script: ApplyiDRACCardAttributes.win

- A) The Lifecycle Controller remote service must be in a “ready” state before executing any other WSMAN commands. The GetRSStatus() method or the GetRemoteServicesAPIStatus() method may be used depending on the version of the LC Management registered profile.
- B) GetiDRACCardAttributes(): ENUMERATE the *DCIM_iDRACCardAttribute* class to view all available attributes. See section 2.2 for a definition of ENUMERATE .
- C) Confirm the *IsReadOnly* field is set to false
- D) ApplyAttributes(): Invoke method to apply attribute(s)
- E) GetiDRACCardAttributes(): ENUMERATE the *DCIM_iDRACCardAttribute* class to view all available attributes and confirm the changes were successful. See section 2.2 for a definition of ENUMERATE .

9.6 Schedule a set iDRAC card attribute(s) operation

Use the following procedure to set a iDRAC attribute(s) using the *SetAttributes* and *CreateTargetConfigJob* methods. This example sets the attribute immediately using the *TIME_NOW* parameter, however the job can be scheduled for execution at a later time.

Applies to: LC2.0+

Prerequisites for script: Set desired values by editing script

Script: SetiDRACCardAttribute.win

- A) The Lifecycle Controller remote service must be in a “ready” state before executing any other WSMAN commands.
GetRemoteServicesAPIStatus():
- B) GetiDRACCardAttributes(): ENUMERATE the *DCIM_iDRACCardAttribute* class to view all available attributes. See section 2.2 for a definition of ENUMERATE .
- C) Confirm the IsReadOnly field is set to false for desired instances
- D) SetAttributes(): Invoke method [ReturnValue = 0]
- E) CreateiDRACConfigJob(): Apply pending values using TIME_NOW paramter
- F) GetiDRACCardAttributes(): ENUMERATE the *DCIM_iDRACCardAttribute* class to view all available attributes and confirm the changes were successful. See section 2.2 for a definition of ENUMERATE .

10 Fan Profile Use Cases

10.1 Discovery of Fan profile support

Use the following procedure below to confirm the existence of fan profile support.

Applies to: LC1.5.0+

Prerequisites for script: none

Script: GetFanProfile.win

- A) The Lifecycle Controller remote service must be in a “ready” state before executing any other WSMAN commands. The GetRSStatus() method or the GetRemoteServicesAPIStatus() method may be used depending on the version of the LC Management registered profile.
- B) GetLCRegisteredProfiles(): ENUMERATE the *DCIM_LCRegisteredProfile* class to view all registered profiles. See section 2.2 for a definition of ENUMERATE .
- C) Search for “RegisteredName=Fan” and note its InstanceID to use in step D)
- D) GetLCRegisteredProfile(): GET the *DCIM_LCRegisteredProfile* instance using the InstanceID from C). See Section 2.3 for a definition of GET .

Results for the *InstanceID* of DCIM:Fan:1.0.0 shown below. If no instance is returned, the profile is not supported.

```
DCIM_LCRegisteredProfile
  AdvertiseTypeDescriptions = WS-Identify, Interop Namespace
  AdvertiseTypes = 1, 1
  InstanceID = DCIM:Fan:1.0.0
  OtherRegisteredOrganization = DCIM
  ProfileRequireLicense = Remote Inventory
  ProfileRequireLicenseStatus = LICENSED
  RegisteredName = Fan
  RegisteredOrganization = 1
  RegisteredVersion = 1.0.0
```

10.2 Inventory of fans in system

Use the following procedure below to list the inventory of all fans in the system.

Applies to: LC1.5.0+

Prerequisites for script: none

Script: GetFanViews.win

- A) The Lifecycle Controller remote service must be in a “ready” state before executing any other WSMAN commands. The GetRSStatus() method or the GetRemoteServicesAPIStatus() method may be used depending on the version of the LC Management registered profile.
- B) GetFanViews(): ENUMERATE the *DCIM_FanView* class to view all instances. See section 2.2 for a definition of ENUMERATE .

The instance information of all available fans will be returned.

10.3 Get the first fan’s information

Use the following procedure to get a single fan instance. The URI for getting particular instance information is deterministic (i.e the *InstanceID* will be unique for each instance).

Applies to: LC1.5.0+

Prerequisites for script:

- Set desired instanceID by editing script

Script: GetFanView.win

- A) The Lifecycle Controller remote service must be in a “ready” state before executing any other WSMAN commands. The GetRSStatus() method or the GetRemoteServicesAPIStatus() method may be used depending on the version of the LC Management registered profile.
- B) GetCPUView(): GET the *DCIM_FanView* instance using the *InstanceID=Fan.embedded.1*. See Section 2.3 for a definition of GET .

The instance of *DCIM_FanView* that contains the information on the first fan will be returned.

11 Persistent Storage Profile Use Cases

11.1 Discovery of Persistent Storage profile support

Use the following procedure below to confirm the existence of Persistent Storage profile support.

Applies to: LC1.4.0+

Prerequisites for script: none

Script: GetPersistentStorageProfile.win

- A) The Lifecycle Controller remote service must be in a “ready” state before executing any other WSMAN commands. The GetRSStatus() method or the GetRemoteServicesAPIStatus() method may be used depending on the version of the LC Management registered profile.
- B) GetLCRegisteredProfiles(): ENUMERATE the *DCIM_LCRegisteredProfile* class to view all registered profiles. See section 2.2 for a definition of ENUMERATE .
- C) Search for “RegisteredName=Persistent Storage” and note its instanceID to use in step D)
- D) GetLCRegisteredProfile(): GET the *DCIM_LCRegisteredProfile* instance using the *InstanceID* from C). See Section 2.3 for a definition of GET .

Results for the *InstanceID* of DCIM:PersistentStorage:1.0.0 shown below. If no instance is returned, the profile is not supported.

```
DCIM_LCRegisteredProfile
  AdvertiseTypeDescriptions = WS-Identify
  AdvertiseTypeDescriptions = Interop Namespace
  AdvertiseTypes = 1
  AdvertiseTypes = 1
  InstanceID = DCIM:PersistentStorage:1.0.0
  OtherRegisteredOrganization = DCIM
  ProfileRequireLicense = Virtual Flash Partitions
  ProfileRequireLicense = Remote Inventory
  ProfileRequireLicenseStatus = LICENSED
  ProfileRequireLicenseStatus = LICENSED
  RegisteredName = Persistent Storage
  RegisteredOrganization = 1
  RegisteredVersion = 1.0.0
```

11.2 Inventory of virtual flash (vFlash) media

Use the following procedure below to list the inventory of all vFlash in the system.

Applies to: LC1.5.0+

Prerequisites for script: none

Script: GetvFlashViews.win

- A) The Lifecycle Controller remote service must be in a “ready” state before executing any other WSMAN commands. The GetRSStatus() method or the GetRemoteServicesAPIStatus() method may be used depending on the version of the LC Management registered profile.

B) GetvFlashViews(): `ENUMERATE` the `DCIM_VFlashView` class to view all instances. See section 2.2 for a definition of `ENUMERATE` .

The instance information of all available virtual flash media will be returned.

11.3 Get the first vFlash's attribute information

The URI for getting particular instance information is deterministic (i.e the `InstanceID` will be unique for each instance)

Applies to: LC1.5.0+

Prerequisites for script:

- Set desired `instanceID` by editing script

Script: GetVFlashView.win

A) The Lifecycle Controller remote service must be in a “ready” state before executing any other WSMAN commands. The `GetRSStatus()` method or the `GetRemoteServicesAPIStatus()` method may be used depending on the version of the LC Management registered profile.

B) GetVFlashView(): `GET` the `DCIM_VFlashView` instance using the `InstanceID=Disk.vFlashCard.1`. See Section 2.3 for a definition of `GET` .

The instance of `DCIM_VFlashView` that contains the information on the first vFlash will be returned

11.4 Inventory of partitions on the virtual flash media

Use the following procedure below to list the inventory of all vFlash partitions in the system.

Applies to: LC1.5.0+

Prerequisites for script: none

Script: GetVFlashPartitionViews.win

A) The Lifecycle Controller remote service must be in a “ready” state before executing any other WSMAN commands. The `GetRSStatus()` method or the `GetRemoteServicesAPIStatus()` method may be used depending on the version of the LC Management registered profile.

B) GetVFlashPartitionViews(): `ENUMERATE` the `DCIM_OpaqueManagementData` class to view all instances. See section 2.2 for a definition of `ENUMERATE` .

The instance information of all available partitions will be returned.

11.5 Initialize virtual flash media

This method is used to initialize or format the virtual flash media device.

Applies to: LC1.5.0+

Prerequisites for script: none

Script: InitVFlash.win

- A) The Lifecycle Controller remote service must be in a “ready” state before executing any other WSMAN commands. The GetRSStatus() method or the GetRemoteServicesAPIStatus() method may be used depending on the version of the LC Management registered profile.
- B) GetVFlashViews(): ENUMERATE the *DCIM_VFlashView* class to view the current value of InitializedState. See section 2.2 for a definition of ENUMERATE .
- C) InitializeMedia(): Invokes the InitializeMedia method on the class *DCIM_PersistentStorageService*
- D) Poll jobstatus for Completed: GET the *InstanceID* of from C). See section 2.3 for a definition of GET .
- E) GetVFlashViews(): ENUMERATE the *DCIM_VFlashView* class to confirm the new value of InitializedState. See section 2.2 for a definition of ENUMERATE .

11.6 Enable virtual flash (vFlash) media

This method is used to enable the virtual flash media device.

Applies to: LC1.5.0+

Prerequisites for script: none

Script: EnableVFlash.win

- A) The Lifecycle Controller remote service must be in a “ready” state before executing any other WSMAN commands. The GetRSStatus() method or the GetRemoteServicesAPIStatus() method may be used depending on the version of the LC Management registered profile.
- B) GetVFlashViews(): ENUMERATE the *DCIM_VFlashView* class to view the current value of VFlashEnabledState property. See section 2.2 for a definition of ENUMERATE .
- C) VFlashStateChange(): Invokes the VFlashStateChange method on the class *DCIM_PersistentStorageService*
- D) Repeat B) to confirm successful execution of the method

11.7 Disable virtual flash (vFlash) media

This method is used to disable the virtual flash media device.

Applies to: LC1.5.0+

Prerequisites for script: none

Script: DisableVFlash.win

- A) The Lifecycle Controller remote service must be in a “ready” state before executing any other WSMAN commands. The GetRSStatus() method or the GetRemoteServicesAPIStatus() method may be used depending on the version of the LC Management registered profile.
- B) GetVFlashViews(): ENUMERATE the *DCIM_VFlashView* class to view the current value of VFlashEnabledState property. See section 2.2 for a definition of ENUMERATE .

- C) VFlashStateChange(): Invokes the VFlashStateChange method on the class DCIM_PersistentStorageService
- D) Repeat B) to confirm successful execution of the method

11.8 Create new partition on virtual flash (vFlash) media

This method is used to create a new partition on the virtual flash media device.

Applies to: LC1.5.0+

Prerequisites for script: set variables by editing script

Script: VFlashCreatePartition.win

- A) The Lifecycle Controller remote service must be in a “ready” state before executing any other WSMAN commands. The GetRSStatus() method or the GetRemoteServicesAPIStatus() method may be used depending on the version of the LC Management registered profile.
- B) GetVFlashPartitionViews(): ENUMERATE the *DCIM_OpaqueManagementData* class to view the current partitions. See section 2.2 for a definition of ENUMERATE .
- C) VFlashStateChange(): Enable vFlash if it is disabled
- D) CreatePartition(): Invokes the CreatePartition method on the class DCIM_PersistentStorageService
- E) Poll jobstatus for Completed: GET the *InstanceID* of from E). See section 2.3 for a definition of GET .
- F) Repeat B) to confirm successful execution of the method

11.9 Create new partition using image

This method is used to create a new partition on the virtual flash media device using an image from a network share.

Applies to: LC1.5.0+

Prerequisites for script: set variables by editing script

Script: VFlashCreatePartitionUsingImage.win

- A) The Lifecycle Controller remote service must be in a “ready” state before executing any other WSMAN commands. The GetRSStatus() method or the GetRemoteServicesAPIStatus() method may be used depending on the version of the LC Management registered profile.
- B) GetVFlashPartitionViews(): ENUMERATE the *DCIM_OpaqueManagementData* class to view the current partitions. See section 2.2 for a definition of ENUMERATE .
- C) CreatePartitionUsingImage(): Invokes the CreatePartitionUsingImage method on the class DCIM_PersistentStorageService
- D) Poll jobstatus for Completed: GET the *InstanceID* of from C). See section 2.3 for a definition of GET .

- E) Repeat B) to confirm successful execution of the method

11.10 Delete existing partition

This method is used to delete a partition from the virtual flash media device.

Applies to: LC1.5.0+

Prerequisites for script: set variables by editing script

Script: VFlashDeletePartition.win

- A) The Lifecycle Controller remote service must be in a “ready” state before executing any other WSMAN commands. The GetRSStatus() method or the GetRemoteServicesAPIStatus() method may be used depending on the version of the LC Management registered profile.
- B) GetVFlashPartitionViews(): ENUMERATE the *DCIM_OpaqueManagementData* class to view the current partitions. See section 2.2 for a definition of ENUMERATE .
- C) DeletePartition(): Invokes the DeletePartition method on the class *DCIM_PersistentStorageService*
- D) GetVFlashPartitionViews(): ENUMERATE the *DCIM_OpaqueManagementData* class to view the current partitions and confirm successful operation. See section 2.2 for a definition of ENUMERATE .

11.11 Format existing partition

This method is used to format a partition on the virtual flash media device.

Applies to: LC1.5.0+

Prerequisites for script: set variables by editing script

Script: VFlashFormatPartition.win

- A) The Lifecycle Controller remote service must be in a “ready” state before executing any other WSMAN commands. The GetRSStatus() method or the GetRemoteServicesAPIStatus() method may be used depending on the version of the LC Management registered profile.
- B) GetVFlashViews(): ENUMERATE the *DCIM_VFlashView* class to view the current partitions, enable vFlash if disabled. See section 2.2 for a definition of ENUMERATE .
- C) FormatPartition(): Invokes the FormatPartition method on the class *DCIM_PersistentStorageService*
- D) Poll jobstatus for Completed: GET the *InstanceID* of from C). See section 2.3 for a definition of GET .
- E) GetVFlashPartitionViews(): ENUMERATE the *DCIM_OpaqueManagementData* class to view the current partitions and confirm successful operation. See section 2.2 for a definition of ENUMERATE .

11.12 Modify existing partition

This method is used to modify a partition on the virtual flash media device.

Applies to: LC1.5.0+

Prerequisites for script: set variables by editing script

Script: VFlashModifyPartition.win

- A) The Lifecycle Controller remote service must be in a “ready” state before executing any other WSMAN commands. The GetRSStatus() method or the GetRemoteServicesAPIStatus() method may be used depending on the version of the LC Management registered profile.
- B) GetVFlashViews(): ENUMERATE the *DCIM_VFlashView* class to view the current partitions. See section 2.2 for a definition of ENUMERATE .
- C) ModifyPartition(): Invokes the ModifyPartition method on the class *DCIM_PersistentStorageService*
- D) GetVFlashPartitionViews(): ENUMERATE the *DCIM_OpaqueManagementData* class to view the current partitions and confirm successful operation. See section 2.2 for a definition of ENUMERATE .

11.13 Attach partition

This method is used to attach a partition on the virtual flash media device.

Applies to: LC1.5.0+

Prerequisites for script: set variables by editing script

Script: VFlashAttachPartition.win

- A) The Lifecycle Controller remote service must be in a “ready” state before executing any other WSMAN commands. The GetRSStatus() method or the GetRemoteServicesAPIStatus() method may be used depending on the version of the LC Management registered profile.
- B) AttachPartition(): Invokes the AttachPartition method on the class *DCIM_PersistentStorageService*
- C) Poll jobstatus for Completed: GET the *InstanceID* of from B). See section 2.3 for a definition of GET .
- D) GetVFlashPartitionViews(): ENUMERATE the *DCIM_OpaqueManagementData* class to view the current partitions and confirm successful operation. See section 2.2 for a definition of ENUMERATE .

11.14 Detach partition

This method is used to detach a partition on the virtual flash media device.

Applies to: LC1.5.0+

Prerequisites for script: set variables by editing script

Script: VFlashDetachPartition.win

- A) The Lifecycle Controller remote service must be in a “ready” state before executing any other WSMAN commands. The GetRSStatus() method or the GetRemoteServicesAPIStatus() method may be used depending on the version of the LC Management registered profile.
- B) DetachPartition(): Invokes the DetachPartition method on the class DCIM_PersistentStorageService
- C) Poll jobstatus for Completed: GET the InstanceID of from B). See section 2.3 for a definition of GET .
- D) GetVFlashPartitionViews(): ENUMERATE the DCIM_OpaqueManagementData class to view the current partitions and confirm successful operation. See section 2.2 for a definition of ENUMERATE .

11.15 Export data from existing partition

This method is used to export data from a partition on the virtual flash media device to a network share.

Applies to: LC1.5.0+

Prerequisites for script: set variables by editing script

Script: VFlashExportDataFromPartition.win

- A) The Lifecycle Controller remote service must be in a “ready” state before executing any other WSMAN commands. The GetRSStatus() method or the GetRemoteServicesAPIStatus() method may be used depending on the version of the LC Management registered profile.
- B) ExportDataFromPartition(): Invokes the ExportDataFromPartition method on the class DCIM_PersistentStorageService
- C) Poll jobstatus for Completed: GET the InstanceID of from B). See section 2.3 for a definition of GET .
- D) GetVFlashPartitionViews(): ENUMERATE the DCIM_OpaqueManagementData class to view the current partitions and confirm successful operation. See section 2.2 for a definition of ENUMERATE .

12 Power State Management Profile Use Cases

12.1 Discovery of Power State Management profile support

Use the following procedure below to confirm the existence of Power State Management profile support. NOTE: Prior to LC2.0.0, this profile resided as a CIM profile, not LC profile.

Applies to: LC1.5.0+

Prerequisites for script: none

Script: GetPowerStateMGMTProfile.win

- A) The Lifecycle Controller remote service must be in a “ready” state before executing any other WSMAN commands. The `GetRSStatus()` method or the `GetRemoteServicesAPIStatus()` method may be used depending on the version of the LC Management registered profile.
- B) [LC1.5.0/LC1.5.1] `GetCIMRegisteredProfiles()`:
[LC2.0.0] `GetLCRegisteredProfiles()`:
ENUMERATE the applicable class to view all registered profiles. See section 2.2 for a definition of ENUMERATE .
- C) Search for “RegisteredName=Power State Management” and note its instanceID to use in step D)
- D) [LC1.5.0/LC1.5.1] `GetCIMRegisteredProfile()`:
[LC2.0.0] `GetLCRegisteredProfile()`:

GET the applicable instance using the *InstanceID* from C). See Section 2.3 for a definition of GET .

Results for the *InstanceID* of `DCIM:PowerStateManagement:1.0.0` shown below. If no instance is returned, the profile is not supported.

```
DCIM_LCRegisteredProfile
  AdvertiseTypeDescriptions = WS-Identify
  AdvertiseTypeDescriptions = Interop Namespace
  AdvertiseTypes = 1
  AdvertiseTypes = 1
  InstanceID = DCIM:PowerStateManagement:1.0.0
  OtherRegisteredOrganization = DCIM
  ProfileRequireLicense
  ProfileRequireLicenseStatus
  RegisteredName = Power State Management
  RegisteredOrganization = 1
  RegisteredVersion = 1.0.0
```

13 Profile Registration Profile Use Cases

13.1 Discovery of Profile Registration profile support

Use the following procedure below to confirm the existence of profile registration profile support.

Applies to: LC2+

Prerequisites for script: none

Script: `GetProfileRegistrationProfile.win`

- A) The Lifecycle Controller remote service must be in a “ready” state before executing any other WSMAN commands.

GetRemoteServicesAPIStatus():

- B) GetLCRegisteredProfiles(): ENUMERATE the *DCIM_LCRegisteredProfile* class to view all registered profiles. See section 2.2 for a definition of ENUMERATE .
- C) Search for “RegisteredName=Profile Registration” and note its instanceID to use in step D)
- D) GetLCRegisteredProfile(): GET the *DCIM_LCRegisteredProfile* instance using the *InstanceID* from C). See Section 2.3 for a definition of GET .

Results for the *InstanceID* of DCIM:ProfileRegistrationProfile shown below. If no instance is returned, the profile is not supported.

```
DCIM_LCRegisteredProfile
  AdvertiseTypeDescriptions = WS-Identify
  AdvertiseTypeDescriptions = Interop Namespace
  AdvertiseTypes = 1
  AdvertiseTypes = 1
  InstanceID = DCIM:ProfileRegistrationProfile
  OtherRegisteredOrganization = DCIM
  ProfileRequireLicense
  ProfileRequireLicenseStatus
  RegisteredName = Profile Registration
  RegisteredOrganization = 1
  RegisteredVersion = 1.0.0
```

14 Simple RAID Profile Use Cases

14.1 Discovery of RAID profile support

Use the following procedure below to confirm the existence of RAID profile support.

Applies to: LC1.5.0+

Prerequisites for script: none

Script: GetRAIDProfile.win

- A) The Lifecycle Controller remote service must be in a “ready” state before executing any other WSMAN commands. The GetRSStatus() method or the GetRemoteServicesAPIStatus() method may be used depending on the version of the LC Management registered profile.
- B) GetLCRegisteredProfiles(): ENUMERATE the *DCIM_LCRegisteredProfile* class to view all registered profiles. See section 2.2 for a definition of ENUMERATE .
- C) Search for “RegisteredName=Simple RAID” and note its instanceID to use in step D)
- D) GetLCRegisteredProfile(): GET the *DCIM_LCRegisteredProfile* instance using the *InstanceID* from C). See Section 2.3 for a definition of GET .

Results for the *InstanceID* of DCIM:SimpleRAID:1.0.0 shown below. If no instance is returned, the profile is not supported.

```
DCIM_LCRegisteredProfile
  AdvertiseTypeDescriptions = WS-Identify
  AdvertiseTypeDescriptions = Interop Namespace
  AdvertiseTypes = 1
  AdvertiseTypes = 1
  InstanceID = DCIM:SimpleRAID:1.0.0
  OtherRegisteredOrganization = DCIM
  ProfileRequireLicense = Remote Firmware Configuration
  ProfileRequireLicense = Remote Inventory
  ProfileRequireLicenseStatus = LICENSED
  ProfileRequireLicenseStatus = LICENSED
  RegisteredName = Simple RAID
  RegisteredOrganization = 1
  RegisteredVersion = 1.2.0
```

14.2 Inventory of RAID controllers in system

Use the following procedure below to list the inventory of all RAID controllers in the system.

Applies to: LC1.5.0+

Prerequisites for script: none

Script: GetRAIDControllerViews.win

- A) The Lifecycle Controller remote service must be in a “ready” state before executing any other WSMAN commands. The GetRSStatus() method or the GetRemoteServicesAPIStatus() method may be used depending on the version of the LC Management registered profile.
- B) GetControllerViews(): ENUMERATE the *DCIM_ControllerView* class to view all instances. See section 2.2 for a definition of ENUMERATE .

The instance information of all available RAID controllers will be returned

14.3 Get the first RAID controller’s information

Use the following procedure to get a single RAID controller instance. The URI for getting particular instance information is deterministic (i.e the *InstanceID* will be unique for each instance).

Applies to: LC1.5.0+

Prerequisites for script:

- Set desired instanceID by editing script

Script: GetRAIDControllerView.win

- A) The Lifecycle Controller remote service must be in a “ready” state before executing any other WSMAN commands. The `GetRSStatus()` method or the `GetRemoteServicesAPIStatus()` method may be used depending on the version of the LC Management registered profile.
- B) `GetControllerView()`: `GET` the `DCIM_ControllerView` instance using the desired `instanceID`. See Section 2.3 for a definition of `GET`.

The instance of `DCIM_ControllerView` that contains the information on the first RAID controller will be returned.

14.4 Inventory of virtual and physical disks in system

Use the following procedure below to list the inventory of all virtual disks and physical disks in the system.

Applies to: LC1.5.0+

Prerequisites for script: none

Script: `GetRAIDDiskInventory.win`

- A) The Lifecycle Controller remote service must be in a “ready” state before executing any other WSMAN commands. The `GetRSStatus()` method or the `GetRemoteServicesAPIStatus()` method may be used depending on the version of the LC Management registered profile.
- B) `GetVirtualDiskViews()`: `ENUMERATE` the `DCIM_VirtualDiskView` class to view all instances. See section 2.2 for a definition of `ENUMERATE`.
- C) `GetPhysicalDiskViews()`: `ENUMERATE` the `DCIM_PhysicalDiskView` class to view all instances. See section 2.2 for a definition of `ENUMERATE`.

The instance information of all available virtual disks and physical disks will be returned.

14.5 Apply pending values for a RAID configuration

View the `CreateRAIDConfigJob()` step in the RAID stacking workflows in Section 4 for a comprehensive example.

14.6 Delete pending values for a RAID configuration

Use the following procedure below to delete pending RAID configurations/values method.

Applies to: LC1.5.0+

Prerequisites for script:

- Set desired RAID FQDD by editing script

Script: `DeletePendingRAIDConfiguration.win`

- A) The Lifecycle Controller remote service must be in a “ready” state before executing any other WSMAN commands. The `GetRSStatus()` method or the `GetRemoteServicesAPIStatus()` method may be used depending on the version of the LC Management registered profile.
- B) `GetControllerViews()`: `ENUMERATE` the `DCIM_ControllerView` class to view all available RAID FQDDs. See section 2.2 for a definition of `ENUMERATE`.

- C) DeletePendingRAIDConfiguration(): Deletes the pending configuration for a particular RAID controller, using a target FQDD.

14.7 Clear old configuration from newly added hard drive

Use the following procedure below to clear old configuration from newly added hard drives.

Applies to: LC1.5.0+

Prerequisites for script:

- Set desired RAID FQDD by editing script

Script: ClearForeignConfig.win

- A) The Lifecycle Controller remote service must be in a “ready” state before executing any other WSMAN commands. The GetRSStatus() method or the GetRemoteServicesAPIStatus() method may be used depending on the version of the LC Management registered profile.
- B) GetControllerViews(): ENUMERATE the *DCIM_ControllerView* class to view all available RAID FQDDs. See section 2.2 for a definition of ENUMERATE .
- C) ClearForeignConfig(): Clears the configuration for a particular RAID controller, using a target FQDD.
- D) CreateRAIDConfigJob(): Apply step C) [ReturnValue=4096].
- E) Poll jobstatus for Completed: GET the *InstanceID* of from D). See section 2.3 for a definition of GET .
- F) The Lifecycle Controller remote service must be in a “ready” state before executing any other WSMAN commands. The GetRSStatus() method or the GetRemoteServicesAPIStatus() method may be used depending on the version of the LC Management registered profile.

The GetRSStatus() method must first poll for ‘reloading’ then poll for ‘ready’, while the GetRemoteServicesAPIStatus() can just poll for ‘ready.’

14.8 Determine available RAID configurations

Use the following procedure below to list the available RAID level configurations for a given set of physical disks.

Applies to: LC1.5.0+

Prerequisites for script:

- Set desired RAID FQDD by editing script

Script: GetRAIDLevels.win

- A) The Lifecycle Controller remote service must be in a “ready” state before executing any other WSMAN commands. The GetRSStatus() method or the GetRemoteServicesAPIStatus() method may be used depending on the version of the LC Management registered profile.

- B) GetControllerViews(): ENUMERATE the *DCIM_ControllerView* class to view all available RAID FQDDs. See section 2.2 for a definition of ENUMERATE .
- C) GetRAIDLevels(): Invoke this method to return desired data
The output will contain the available RAID level configurations for the given physical disk selection

14.9 Determine available physical disks for a RAID configuration

Use the following procedure below to list the available physical disks for a given RAID level configurations.

Applies to: LC1.5.0+

Prerequisites for script:

- Set desired RAID FQDD by editing script

Script: GetRAIDAvailableDisks.win

- A) The Lifecycle Controller remote service must be in a “ready” state before executing any other WSMAN commands. The GetRSStatus() method or the GetRemoteServicesAPIStatus() method may be used depending on the version of the LC Management registered profile.
- B) GetControllerViews(): ENUMERATE the *DCIM_ControllerView* class to view all available RAID FQDDs. See section 2.2 for a definition of ENUMERATE .
- C) GetAvailableDisks(): Invoke this method which will return the desired data
The output will contain the available physical disks for the given RAID level.

14.10 Check available virtual disk parameters for a given RAID level and set of physical disks

Use the following procedure below to list the available sizes and default values for a given RAID level configurations.

Applies to: LC1.5.0+

Prerequisites for script:

- Set desired RAID controller FQDD, physical disk FQDDs, and RAID level parameters by editing script

Script: CheckVDValues.win

- A) The Lifecycle Controller remote service must be in a “ready” state before executing any other WSMAN commands. The GetRSStatus() method or the GetRemoteServicesAPIStatus() method may be used depending on the version of the LC Management registered profile.
- B) GetControllerViews(): ENUMERATE the *DCIM_ControllerView* class to view all available RAID FQDDs. See section 2.2 for a definition of ENUMERATE .
- C) GetPhysicalDiskViews(): ENUMERATE the *DCIM_PhysicalDiskView* class to view all available physical disk FQDDs. See section 2.2 for a definition of ENUMERATE .

D) CheckVDValues(): Invoke this method to return desired data

The output will contain the available sizes and default values for the given RAID level and set of physical disks

14.11 Create a virtual disk

View the RAID stacking workflows in Section 4 for a comprehensive example.

14.12 Determine available physical disks to be used as a hotspare

The GetDHSDisks() method is used to determine possible physical disks to be used as a hotspare.

Applies to: LC1.5.0+

Prerequisites for script:

- Set desired RAID controller FQDD, physical disk FQDDs, and RAID level parameters by editing script

Script: GetDHSDisks.win

- A) The Lifecycle Controller remote service must be in a “ready” state before executing any other WSMAN commands. The GetRSStatus() method or the GetRemoteServicesAPIStatus() method may be used depending on the version of the LC Management registered profile.
- B) GetControllerViews(): ENUMERATE the *DCIM_ControllerView* class to view all available RAID FQDDs. See section 2.2 for a definition of ENUMERATE .
- C) GetDHSDisks(): Invoke this method to return desired data
- The output will contain the available physical disks for use as a hotspare.

14.13 Assign a physical disk as a hotspare

View the RAID stacking workflows in Section 4 for a comprehensive example.

14.14 Delete a virtual disk from the system

The following script can be used to delete an existing virtual disk from a system.

Applies to: LC1.5.0+

Prerequisites for script:

- Set desired RAID virtual disk FQDD by editing script

Script: DeleteVirtualDisk.win

- A) The Lifecycle Controller remote service must be in a “ready” state before executing any other WSMAN commands. The GetRSStatus() method or the GetRemoteServicesAPIStatus() method may be used depending on the version of the LC Management registered profile.
- B) GetControllerViews(): ENUMERATE the *DCIM_ControllerView* class to view all available RAID FQDDs. See section 2.2 for a definition of ENUMERATE .

- C) `GetVirtualDiskViews()`: `ENUMERATE` the `DCIM_VirtualDiskView` class to view all available virtual disk FQDDs. See section 2.2 for a definition of `ENUMERATE`.
- D) `DeleteVirtualDisk ()`: Invoke this method to delete the VD
- E) `CreateRAIDConfigJob()`: Apply step D) [ReturnValue=4096]
- F) Poll jobstatus for Completed: `GET` the `InstanceID` of from E). See section 2.3 for a definition of `GET`.
- G) The Lifecycle Controller remote service must be in a “ready” state before executing any other WSMAN commands. The `GetRSStatus()` method or the `GetRemoteServicesAPIStatus()` method may be used depending on the version of the LC Management registered profile.

The `GetRSStatus()` method must first poll for ‘reloading’ then poll for ‘ready’, while the `GetRemoteServicesAPIStatus()` can just poll for ‘ready.’
- H) `ENUMERATE` the `DCIM_VirtualDiskView` class to ensure successful virtual disk deletion. See section 2.2 for a definition of `ENUMERATE`.

Confirm successful execution of the method by listing the virtual disks. The deleted virtual disk should not be displayed.

14.15 Delete all virtual disks and unassign all hotspares

View the RAID stacking workflows in Section 4 for a comprehensive example.

14.16 Convert physical disks to RAID state

The `ConvertToRAID()` method is used to convert a physical disks in Non-RAID state to a state usable for RAID. After the method is successfully executed the `PendingValue` property of `RAIDPDState` should reflect the pending changes. After the `CreateTargetedConfigJob` method is successfully executed the `DCIM_PhysicalDiskView.RAIDStatus` property of that physical disk should reflect the new state. One can expect this operation to take up to 15 minutes depending on system configuration.

Applies to: LC2+

Prerequisites for script:

- Set desired RAID physical disk FQDD by editing script

Script: `ConvertToRAID.win`

- A) The Lifecycle Controller remote service must be in a “ready” state before executing any other WSMAN commands.

`GetRemoteServicesAPIStatus()`

- B) `GetControllerViews()`: `ENUMERATE` the `DCIM_ControllerView` class to view all available RAID FQDDs. See section 2.2 for a definition of `ENUMERATE` .
- C) `GetPhysicalDiskViews()`: `ENUMERATE` the `DCIM_PhysicalDiskView` class to view all available physical disk FQDDs. See section 2.2 for a definition of `ENUMERATE` .

Note the value of the `RaidStatus` parameter of the desired physical disk.

- D) `ConvertToRAID()`: Invoke this method
- E) `CreateRAIDConfigJob()`: Apply step D) [`ReturnValue=4096`]
- F) Poll jobstatus for Completed: `GET` the `InstanceID` of from E). See section 2.3 for a definition of `GET` .
- G) The Lifecycle Controller remote service must be in a “ready” state before executing any other WSMAN commands.

`GetRemoteServicesAPIStatus()`

- H) `GetPhysicalDiskViews()`: `ENUMERATE` the `DCIM_PhysicalDiskView` class to view all available physical disk FQDDs. See section 2.2 for a definition of `ENUMERATE` .

Note the new value of the `RaidStatus` parameter of the desired physical disk.

14.17 Convert physical disks to non-RAID state

The `ConvertToNonRAID()` method is used to convert a set of physical disks in RAID state to a state not usable for RAID. After the method is successfully executed the `PendingValue` property of `RAIDPDState` should reflect the pending changes. After the `CreateTargetedConfigJob` method is successfully executed the `DCIM_PhysicalDiskView.RAIDStatus` property of that physical disk should reflect the new state. One can expect this operation to take up to 15 minutes depending on system configuration.

Applies to: LC2+

Prerequisites for script:

- Set desired RAID physical disk FQDD by editing script

Script: `ConvertToNonRAID.win`

- A) The Lifecycle Controller remote service must be in a “ready” state before executing any other WSMAN commands.

`GetRemoteServicesAPIStatus()`

- B) `GetControllerViews()`: `ENUMERATE` the `DCIM_ControllerView` class to view all available RAID FQDDs. See section 2.2 for a definition of `ENUMERATE` .
- C) `GetPhysicalDiskViews()`: `ENUMERATE` the `DCIM_PhysicalDiskView` class to view all available physical disk FQDDs. See section 2.2 for a definition of `ENUMERATE` .

Note the value of the *RaidStatus* parameter of the desired physical disk.

- D) ConvertToNonRAID(): Invoke this method
- E) CreateRAIDConfigJob(): Apply step D) [ReturnValue=4096]
- F) Poll jobstatus for Completed: GET the *InstanceID* of from E). See section 2.3 for a definition of GET .
- G) The Lifecycle Controller remote service must be in a “ready” state before executing any other WSMAN commands.

GetRemoteServicesAPIStatus()

- H) GetPhysicalDiskViews(): ENUMERATE the *DCIM_PhysicalDiskView* class to view all available physical disk FQDDs. See section 2.2 for a definition of ENUMERATE .

Note the new value of the *RaidStatus* parameter of the desired physical disk.

15 Record Log Profile Use Cases

15.1 Discovery of Record Log profile support

Use the following procedure below to confirm the existence of Record Log profile support.

Applies to: LC1.5.0+

Prerequisites for script: none

Script: GetRecordLogProfile.win

- A) The Lifecycle Controller remote service must be in a “ready” state before executing any other WSMAN commands. The GetRSStatus() method or the GetRemoteServicesAPIStatus() method may be used depending on the version of the LC Management registered profile.
- B) GetLCRegisteredProfiles(): ENUMERATE the *DCIM_LCRegisteredProfile* class to view all registered profiles. See section 2.2 for a definition of ENUMERATE .
- C) Search for “RegisteredName=Record log” and note its instanceID to use in step D)
- D) GetLCRegisteredProfile(): GET the *DCIM_LCRegisteredProfile* instance using the *InstanceID* from C). See Section 2.3 for a definition of GET .

Results for the *InstanceID* of DCIM:RecordLog:1.0.0 shown below. If no instance is returned, the profile is not supported.

```
DCIM_LCRegisteredProfile
  AdvertiseTypeDescriptions = WS-Identify
  AdvertiseTypeDescriptions = Interop Namespace
  AdvertiseTypes = 1
  AdvertiseTypes = 1
```

InstanceID = DCIM:RecordLog:1.0.0
OtherRegisteredOrganization = DCIM
ProfileRequireLicense
ProfileRequireLicenseStatus
RegisteredName = Record Log
RegisteredOrganization = 1
RegisteredVersion = 1.0.0

15.2 List Lifecycle record logs

Use the following procedure below to list the inventory of all LCRecordLog instances in the system.

Applies to: LC1.5.0+

Prerequisites for script: none

Script: GetLCRecordLogs.win

- A) The Lifecycle Controller remote service must be in a “ready” state before executing any other WSMAN commands. The GetRSStatus() method or the GetRemoteServicesAPIStatus() method may be used depending on the version of the LC Management registered profile.
- B) GetLCRecordLogs(): ENUMERATE the *DCIM_LCRecordLog* class to view all instances. See section 2.2 for a definition of ENUMERATE .

The instance information of all available LCRecordLog will be returned

15.3 List Lifecycle record log capabilities

Use the following procedure below to list the inventory of all LCRecordLogCapabilities instances in the system.

Applies to: LC1.5.0+

Prerequisites for script: none

Script: GetLCRecordLogCapabilities.win

- A) The Lifecycle Controller remote service must be in a “ready” state before executing any other WSMAN commands. The GetRSStatus() method or the GetRemoteServicesAPIStatus() method may be used depending on the version of the LC Management registered profile.
- B) GetLCRecordLogCapabilities(): ENUMERATE the *DCIM_LCRecordLogCapabilities* class to view all instances. See section 2.2 for a definition of ENUMERATE .

The instance information of all available LCRecordLogCapabilities will be returned

15.4 List Lifecycle log entries

Use the following procedure below to list the inventory of all LCLogEntry instances in the system.

Applies to: LC1.5.0+

Prerequisites for script:

- Due to the large amount of data returned by this enumeration, winRM settings may need to be changed as described in the section 1.2

Script: GetLCLogEntries.win

- A) The Lifecycle Controller remote service must be in a “ready” state before executing any other WSMAN commands. The GetRSStatus() method or the GetRemoteServicesAPIStatus() method may be used depending on the version of the LC Management registered profile.
- B) GetLCLogEntries(): ENUMERATE the *DCIM_LCLogEntry* class to view all instances. See section 2.2 for a definition of ENUMERATE .

The instance information of all available LCLogEntry will be returned

15.5 Set and get comment in Lifecycle log entries

Use the following procedure below to ‘Get’and ‘Set’ the instance of *DCIM_LCLogEntry* with the *Comment* that needs to be added. This is accomplished using an intrinsic set/put operation on the *DCIM_LCLogEntry* instance at the *Comment* property.

Applies to: LC1.5.0+

Prerequisites for script:

- Due to the large amount of data returned by this enumeration, winRM settings may need to be changed as described in the section 1.2
- Set desired instanceID by editing script

Script: SetLCLogEntryComment.win

- A) The Lifecycle Controller remote service must be in a “ready” state before executing any other WSMAN commands. The GetRSStatus() method or the GetRemoteServicesAPIStatus() method may be used depending on the version of the LC Management registered profile.
- B) GetLCLogEntries(): ENUMERATE the *DCIM_LCLogEntry* class to view all instances of the class LCLogEntry. See section 2.2 for a definition of ENUMERATE .
- C) GetLCLogEntry(): GET the desired *InstanceID* of from B). See section 2.3 for a definition of GET . This will display the current comment.
- D) SetLCLogEntryComment(): Set the desired comment into the *InstanceID* of from C)
- E) GetLCLogEntry(): GET the desired *InstanceID* of from B) to confirm new comment

15.6 List system event record logs

Use the following procedure below to list the inventory of all SELRecordLog instances in the system.

Applies to: LC1.5.0+

Prerequisites for script: none

Script: GetSystemEventLogs.win

- A) The Lifecycle Controller remote service must be in a “ready” state before executing any other WSMAN commands. The GetRSStatus() method or the GetRemoteServicesAPIStatus() method may be used depending on the version of the LC Management registered profile.
- B) GetSystemEventLogs(): `ENUMERATE` the `DCIM_SELRecordLog` class to view all instances. See section 2.2 for a definition of `ENUMERATE` .

The instance information of all available SELRecordLog will be returned

15.7 List system event record log capabilities

Use the following procedure below to list the inventory of all SELRecordLogCapabilities instances in the system.

Applies to: LC1.5.0+

Prerequisites for script: none

Script: GetSystemEventLogCapabilities.win

- A) The Lifecycle Controller remote service must be in a “ready” state before executing any other WSMAN commands. The GetRSStatus() method or the GetRemoteServicesAPIStatus() method may be used depending on the version of the LC Management registered profile.
- B) GetSystemEventLogCapabilities(): `ENUMERATE` the `DCIM_SELRecordLogCapabilities` class to view all instances. See section 2.2 for a definition of `ENUMERATE` .

The instance information of all available SELRecordLogCapabilities will be returned

15.8 List system event log entries

Use the following procedure below to list the inventory of all SELLogEntry instances in the system.

Applies to: LC1.5.0+

Prerequisites for script: none

Script: GetSystemEventLogEntries.win

- A) The Lifecycle Controller remote service must be in a “ready” state before executing any other WSMAN commands. The GetRSStatus() method or the GetRemoteServicesAPIStatus() method may be used depending on the version of the LC Management registered profile.
- B) GetSystemEventLogEntries(): ENUMERATE the *DCIM_SELLogEntry* class to view all instances. See section 2.2 for a definition of ENUMERATE .

The instance information of all available SELLogEntry will be returned

16 Role Based Authorization Profile (RBAP) use cases

16.1 Discovery of RBAP profile support

Use the following procedure below to confirm the existence of Role Based Authorization profile support. NOTE: Prior to LC2.0.0, this profile resided as a CIM profile, not LC profile.

Applies to: LC1.5.0+

Prerequisites for script: none

Script: GetRBAPProfile.win

- A) The Lifecycle Controller remote service must be in a “ready” state before executing any other WSMAN commands. The GetRSStatus() method or the GetRemoteServicesAPIStatus() method may be used depending on the version of the LC Management registered profile.
- B) [LC1.5.0/LC1.5.1]GetCIMRegisteredProfiles():
[LC2.0.0]GetLCRegisteredProfiles():

ENUMERATE the applicable class to view all registered profiles. See section 2.2 for a definition of ENUMERATE .

- C) Search for “RegisteredName= Role Based Authorization” and note its instanceID to use in step D)

- D) [LC1.5.0/LC1.5.1] GetCIMRegisteredProfile():

[LC2.0.0] GetLCRegisteredProfile():

GET the applicable instance using the *InstanceID* from C). See Section 2.3 for a definition of GET .

Results for the *InstanceID* of *DCIM:RoleBasedAuthorization:1.0.0* shown below. If no instance is returned, the profile is not supported.

```
DCIM_LCRegisteredProfile
  AdvertiseTypeDescriptions = WS-Identify
  AdvertiseTypeDescriptions = Interop Namespace
  AdvertiseTypes = 1
  AdvertiseTypes = 1
  InstanceID = DCIM:RoleBasedAuthorization:1.0.0
```

OtherRegisteredOrganization = DCIM
ProfileRequireLicense
ProfileRequireLicenseStatus
RegisteredName = Role Based Authorization
RegisteredOrganization = 1
RegisteredVersion = 1.0.0

16.2 Discovery of users with assigned LAN privileges

Enumerate the *DCIM_IPMIRBAIdentityMemberOfCollection* class to view all IPMI LAN identities that are assigned a role.

Applies to: LC1.5.0+

Prerequisites for script: none

Script: *GetUsersAssignedLANPrivileges.win*

- A) The Lifecycle Controller remote service must be in a “ready” state before executing any other WSMAN commands. The *GetRSStatus()* method or the *GetRemoteServicesAPIStatus()* method may be used depending on the version of the LC Management registered profile.
- B) *GetUsersAssignedLANPrivileges()*: `ENUMERATE` the *DCIM_IPMIRBAIdentityMemberOfCollection* class to view all instances. See section 2.2 for a definition of `ENUMERATE` .

The associations between all LAN Identities and IPMI Roles will be returned.

16.3 Discovery of users with assigned serial over LAN privileges

Enumerate the *DCIM_IPMISOLRBAIdentityMemberOfCollection* class to view all serial identities that are assigned a role.

Applies to: LC1.5.0+

Prerequisites for script: none

Script: *GetUsersAssignedSerialOverLANPrivileges.win*

- A) The Lifecycle Controller remote service must be in a “ready” state before executing any other WSMAN commands. The *GetRSStatus()* method or the *GetRemoteServicesAPIStatus()* method may be used depending on the version of the LC Management registered profile.
- B) *GetUsersAssignedSerialOverLANPrivileges()*: `ENUMERATE` the *DCIM_IPMISOLRBAIdentityMemberOfCollection* class to view all instances. See section 2.2 for a definition of `ENUMERATE` .

The associations between the serial Identities and IPMI SOL Role will be returned

16.4 Discovery of users with assigned CLP privileges

Enumerate the *DCIM_CLPRBAIdentityMemberOfCollection* class to view all CLP identities that are assigned a role.

Applies to: LC1.5.0+

Prerequisites for script: none

Script: GetUsersAssignedCLPPrivileges.win

- A) The Lifecycle Controller remote service must be in a “ready” state before executing any other WSMAN commands. The GetRSStatus() method or the GetRemoteServicesAPIStatus() method may be used depending on the version of the LC Management registered profile.
- B) GetUsersAssignedCLPPrivileges(): ENUMERATE the *DCIM_CLPRBAIdentityMemberOfCollection* class to view all instances. See section 2.2 for a definition of ENUMERATE .

The associations between all CLP Identities and CLP Roles will be returned.

17 Service Processor Profile Use Cases

17.1 Discovery of Service Processor profile support

Use the following procedure below to confirm the existence of Service Processor profile support.

Applies to: LC1.5.0+

Prerequisites for script: none

Script: GetServiceProcessorProfile.win

- A) The Lifecycle Controller remote service must be in a “ready” state before executing any other WSMAN commands. The GetRSStatus() method or the GetRemoteServicesAPIStatus() method may be used depending on the version of the LC Management registered profile.
- B) GetLCRegisteredProfiles(): ENUMERATE the *DCIM_LCRegisteredProfile* class to view all registered profiles. See section 2.2 for a definition of ENUMERATE .
- C) Search for “RegisteredName=Service Processor” and note its InstanceID to use in step D)
- D) GetLCRegisteredProfile(): GET the *DCIM_LCRegisteredProfile* instance using the *InstanceID* from C). See Section 2.3 for a definition of GET .

Results for the *InstanceID* of DCIM: SystemInfo:1.0.0 shown below. If no instance is returned, the profile is not supported.

```
DCIM_LCRegisteredProfile
  AdvertiseTypeDescriptions = WS-Identify
  AdvertiseTypeDescriptions = Interop Namespace
  AdvertiseTypes = 1
  AdvertiseTypes = 1
  InstanceID = DCIM:ServiceProcessor:1.0.0
  OtherRegisteredOrganization = DCIM
  ProfileRequireLicense
  ProfileRequireLicenseStatus
  RegisteredName = Service Processor
  RegisteredOrganization = 1
```

RegisteredVersion = 1.0.0

18 Simple NIC Profile Use Cases

18.1 Discovery of Simple NIC profile support

Use the following procedure below to confirm the existence of Simple NIC profile support.

Applies to: LC1.5.0+

Prerequisites for script: none

Script: GetNICProfile.win

- A) The Lifecycle Controller remote service must be in a “ready” state before executing any other WSMAN commands. The GetRSStatus() method or the GetRemoteServicesAPIStatus() method may be used depending on the version of the LC Management registered profile.
- B) GetLCRegisteredProfiles(): `ENUMERATE` the *DCIM_LCRegisteredProfile* class to view all registered profiles. See section 2.2 for a definition of `ENUMERATE` .
- C) Search for “RegisteredName=Simple NIC” and note its instanceID to use in step D)
- D) GetLCRegisteredProfile(): `GET` the *DCIM_LCRegisteredProfile* instance using the *InstanceID* from C). See Section 2.3 for a definition of `GET` .

Results for the *InstanceID* of DCIM: SimpleNIC:1.0.0 shown below. If no instance is returned, the profile is not supported.

```
DCIM_LCRegisteredProfile
  AdvertiseTypeDescriptions = WS-Identify
  AdvertiseTypeDescriptions = Interop Namespace
  AdvertiseTypes = 1
  AdvertiseTypes = 1
  InstanceID = DCIM:SimpleNIC:1.0.0
  OtherRegisteredOrganization = DCIM
  ProfileRequireLicense = Remote Firmware Configuration
  ProfileRequireLicense = Remote Inventory
  ProfileRequireLicense = Device Monitoring
  ProfileRequireLicenseStatus = LICENSED
  ProfileRequireLicenseStatus = LICENSED
  ProfileRequireLicenseStatus = LICENSED
  RegisteredName = Simple NIC
  RegisteredOrganization = 1
  RegisteredVersion = 1.2.0
```

18.2 Inventory of NICs in system

Use the following procedure below to list the inventory of all NICs in the system.

Applies to: LC1.5.0+

Prerequisites for script: none

Script: GetNICViews.win

- A) The Lifecycle Controller remote service must be in a “ready” state before executing any other WSMAN commands. The GetRSStatus() method or the GetRemoteServicesAPIStatus() method may be used depending on the version of the LC Management registered profile.
- B) GetNICViews(): `ENUMERATE` the `DCIM_NICView` class to view all instances. See section 2.2 for a definition of `ENUMERATE` .

The instance information of all available NICs will be returned.

18.3 Get the first NIC’s information

Use the following procedure to get a single NIC instance. The URI for getting particular instance information is deterministic (i.e the *InstanceID* will be unique for each instance).

Applies to: LC1.5.0+

Prerequisites for script:

- Set desired instanceID by editing script

Script: GetNICView.win

- A) The Lifecycle Controller remote service must be in a “ready” state before executing any other WSMAN commands. The GetRSStatus() method or the GetRemoteServicesAPIStatus() method may be used depending on the version of the LC Management registered profile.
- B) GetNICView(): `GET` the `DCIM_NICView` instance using an instanceID, such as *NIC.Mezzanine.2B-1*. See Section 2.3 for a definition of `GET` .

The instance of `DCIM_NICView` that contains the information on the first NIC will be returned.

18.4 List all NIC attributes

Use the following procedure below to view all available attributes and possible values of all NICs in the system.

Applies to: LC1.5.0+

Prerequisites for script: none

Script: GetAllNICAttributes.win

- A) The Lifecycle Controller remote service must be in a “ready” state before executing any other WSMAN commands. The GetRSStatus() method or the GetRemoteServicesAPIStatus() method may be used depending on the version of the LC Management registered profile.
- B) GetNICAttributes(): `ENUMERATE` the `DCIM_NICAttribute` class to view all instances. See section 2.2 for a definition of `ENUMERATE` .

18.5 Delete pending NIC values

Use the following procedure below to delete pending NIC configurations/values set by the `setAttribute(s)` method.

Applies to: LC1.5.0+

Prerequisites for script:

- Set desired NIC FQDD

Script: DeletePendingNICConfiguration.win

- A) The Lifecycle Controller remote service must be in a “ready” state before executing any other WSMAN commands. The GetRSStatus() method or the GetRemoteServicesAPIStatus() method may be used depending on the version of the LC Management registered profile.
- B) GetNICViews(): ENUMERATE the *DCIM_NICView* class to view all available NIC FQDDs. See section 2.2 for a definition of ENUMERATE .
- C) DeletePendingNICConfiguration(): Deletes the pending configuration for a particular NIC, using a target FQDD such as NIC.Embedded.1-1.

A return message of “No pending data present to delete” indicates that there is no pending NIC configuration to delete for the respective FQDD.

18.6 Discovery of NIC capabilities

Use the following procedure below to determine the capabilities of NIC cards such as QLogic, Broadcom, and Intel.

Applies to: LC1.5.0+

Prerequisites for script:

- none

Script: NICcapEnable.win

- A) The Lifecycle Controller remote service must be in a “ready” state before executing any other WSMAN commands. The GetRSStatus() method or the GetRemoteServicesAPIStatus() method may be used depending on the version of the LC Management registered profile.
- B) GetNICCapabilities(): ENUMERATE the *DCIM_NICCapabilities* class to view all instances of the class. See section 2.2 for a definition of ENUMERATE . If instances are returned, go to end of script as the capabilities are published
- C) GetNICViews(): ENUMERATE the *DCIM_NICView* class to view all available NIC instances. See section 2.2 for a definition of ENUMERATE . If no instances are returned, go to end of script as no NICs are present.
- D) GetSystemViews(): ENUMERATE the *DCIM_SystemView* class. See section 2.2 for a definition of ENUMERATE . If the “PowerState” field is equal to 8, power on system.
- E) RequestPowerStateChange(): Power on the system using PowerState=2

- F) The Lifecycle Controller remote service must be in a “ready” state before executing any other WSMAN commands. The `GetRSStatus()` method or the `GetRemoteServicesAPIStatus()` method may be used depending on the version of the LC Management registered profile.
 - When the system is ready, continue
- G) `GetNICCapabilities()`: `ENUMERATE` the `DCIM_NICCapabilities` class to view all instances of the class. See section 2.2 for a definition of `ENUMERATE` . If instances are returned, go to end of script as the capabilities are published
- H) `RequestPowerStateChange()`: Power off the system using `PowerState=8`
 - NOTE: If an operating system has been installed, the system will boot into it. It may be desired to wait until the OS boot is complete before performing a graceful shutdown.

19 Software Update Profile use cases

19.1 Discovery of Software Update profile support

Use the following procedure below to confirm the existence of software update profile support.

Applies to: LC1.5.0+

Prerequisites for script: none

Script: `GetSoftwareUpdateProfile.win`

- A) The Lifecycle Controller remote service must be in a “ready” state before executing any other WSMAN commands. The `GetRSStatus()` method or the `GetRemoteServicesAPIStatus()` method may be used depending on the version of the LC Management registered profile.
- B) `GetLCRegisteredProfiles()`: `ENUMERATE` the `DCIM_LCRegisteredProfile` class to view all registered profiles. See section 2.2 for a definition of `ENUMERATE` .
- C) Search for “RegisteredName=Software Update” and note its `InstanceID` to use in step D)
- D) `GetLCRegisteredProfile()`: `GET` the `DCIM_LCRegisteredProfile` instance using the `InstanceID` from C). See Section 2.3 for a definition of `GET` .

Results for the `InstanceID` of `DCIM: SoftwareUpdate:1.0.0` shown below. If no instance is returned, the profile is not supported.

```
DCIM_LCRegisteredProfile
  AdvertiseTypeDescriptions = WS-Identify
  AdvertiseTypeDescriptions = Interop Namespace
  AdvertiseTypes = 1
  AdvertiseTypes = 1
  InstanceID = DCIM:SoftwareUpdate:1.0.0
  OtherRegisteredOrganization = DCIM
  ProfileRequireLicense = Remote Firmware Update
  ProfileRequireLicenseStatus = LICENSED
  RegisteredName = Software Update
```

RegisteredOrganization = 1
RegisteredVersion = 1.0.0

20 Job Control Profile Use Cases

20.1 Discovery of Job Control profile support

Use the following procedure below to confirm the existence of Job Control profile support.

Applies to: LC1.4.0+

Prerequisites for script: none

Script: GetJobControlProfile.win

- A) The Lifecycle Controller remote service must be in a “ready” state before executing any other WSMAN commands. The GetRSStatus() method or the GetRemoteServicesAPIStatus() method may be used depending on the version of the LC Management registered profile.
- B) GetLCRegisteredProfiles(): ENUMERATE the *DCIM_LCRegisteredProfile* class to view all registered profiles. See section 2.2 for a definition of ENUMERATE .
- C) Search for “RegisteredName=Job Control” and note its InstanceID to use in step D)
- D) GetLCRegisteredProfile(): GET the *DCIM_LCRegisteredProfile* instance using the *InstanceID* from C). See Section 2.3 for a definition of GET .

Results for the *InstanceID* of DCIM:JobControl:1.0.0 shown below. If no instance is returned, the profile is not supported.

```
DCIM_LCRegisteredProfile
  AdvertiseTypeDescriptions = WS-Identify
  AdvertiseTypeDescriptions = Interop Namespace
  AdvertiseTypes = 1
  AdvertiseTypes = 1
  InstanceID = DCIM:JobControl:1.0.0
  OtherRegisteredOrganization = DCIM
  ProfileRequireLicense = Remote Firmware Configuration
  ProfileRequireLicenseStatus = LICENSED
  RegisteredName = Job Control
  RegisteredOrganization = 1
  RegisteredVersion = 1.2.0
```

20.2 List all jobs in job store

Getting all the jobs in the job store is a matter of confirming the system is in a ready state and then enumerating the *DCIM_LifecycleJob* class to view all available instances of the class.

Applies to: LC1.4.0+

Prerequisites for script: none

Script: ListAllJobs.win

- A) The Lifecycle Controller remote service must be in a “ready” state before executing any other WSMAN commands. The GetRSStatus() method or the GetRemoteServicesAPIStatus() method may be used depending on the version of the LC Management registered profile.
- B) ENUMERATE the *DCIM_LifecycleJob* class to view all jobs. See section 2.2 for a definition of ENUMERATE .

20.3 Get one job’s information

The URI for getting particular instance information is deterministic (i.e the *InstanceID* will be unique for each instance). Job IDs are usually obtained directly from a concrete job, reboot job, or create target config job operations.

Applies to: LC1.3.0

Prerequisites for script:

- Set desired job variable by editing script

Script: Get1Job.win

- A) The Lifecycle Controller remote service must be in a “ready” state before executing any other WSMAN commands. The GetRSStatus() method or the GetRemoteServicesAPIStatus() method may be used depending on the version of the LC Management registered profile.
- B) Use the instanceID from a concrete job, reboot job, or create target config job operation. Note: Reboot job IDs start with RID_ instead of JID_. See section 2.3 for a definition of GET .

The instance of *DCIM_LifecycleJob* that contains the information on the job will be returned.

20.4 Delete all jobs from job store (job queue) using “JID_CLEARALL”

This workflow deletes all jobs from the job queue using by passing JID_CLEARALL as the jobID.

[LC1.5.x and prior] Running this command also restarts remote services.

Applies to: LC1.3.0

Prerequisites for script: none

Script: DeleteAllJobs.win

- A) The Lifecycle Controller remote service must be in a “ready” state before executing any other WSMAN commands. The GetRSStatus() method or the GetRemoteServicesAPIStatus() method may be used depending on the version of the LC Management registered profile.
- B) DeleteJobQueue(): Delete all jobs from the job store by setting JobID="JID_CLEARALL"
- C) [LC1.5.x and prior] The The GetRSStatus() method or the GetRemoteServicesAPIStatus() method may be used depending on the version of the LC Management registered profile.

- D) [LC1.5.x and prior] The remote service will get reset upon invoking the delete job queue command. The GetRSStatus() method or the GetRemoteServicesAPIStatus() method may be used depending on the version of the LC Management registered profile to determine when the remote service is ready.

The GetRSStatus() method must first poll for 'reloading' then poll for 'ready', while the GetRemoteServicesAPIStatus() can just poll for 'ready.'

20.5 Delete one job from job store

This workflow deletes one job from the job store (job queue). The user must specify which job ID or reboot ID to be deleted.

Applies to: LC1.3.0

Prerequisites for script: Specify job ID to be deleted by editing script

Script: DeleteOneJob.win

- A) The Lifecycle Controller remote service must be in a "ready" state before executing any other WSMAN commands. The GetRSStatus() method or the GetRemoteServicesAPIStatus() method may be used depending on the version of the LC Management registered profile.
- B) DeleteJobQueue(): Delete specified job from the job store by setting JobID equal to the job ID (JID_01234) or reboot ID (RID_01234).
- C) GetLifecycleJobs(): List all remaining jobs in job store

21 Memory Profile Use Cases

21.1 Discovery of Memory profile support

Use the following procedure below to confirm the existence of memory profile support.

Applies to: LC1.5.0+

Prerequisites for script: none

Script: GetMemoryProfile.win

- A) The Lifecycle Controller remote service must be in a "ready" state before executing any other WSMAN commands. The GetRSStatus() method or the GetRemoteServicesAPIStatus() method may be used depending on the version of the LC Management registered profile.
- B) GetLCRegisteredProfiles(): ENUMERATE the *DCIM_LCRegisteredProfile* class to view all registered profiles. See section 2.2 for a definition of ENUMERATE .
- C) Search for "RegisteredName=Memory" and note its instanceID to use in step D)
- D) GetLCRegisteredProfile(): GET the *DCIM_LCRegisteredProfile* instance using the *InstanceID* from C). See Section 2.3 for a definition of GET .

Results for the *InstanceID* of DCIM:Memory:1.0.0 shown below. If no instance is returned, the profile is not supported.

NOTE: 12G example output shown below

```
DCIM_LCRegisteredProfile
  AdvertiseTypeDescriptions = WS-Identify
  AdvertiseTypeDescriptions = Interop Namespace
  AdvertiseTypes = 1
  AdvertiseTypes = 1
  InstanceID = DCIM:Memory:1.0.0
  OtherRegisteredOrganization = DCIM
  ProfileRequireLicense = Remote Inventory
  ProfileRequireLicenseStatus = LICENSED
  RegisteredName = Memory
  RegisteredOrganization = 1
  RegisteredVersion = 1.1.0
```

21.2 Inventory of memory in system

Use the following procedure below to list the inventory of all memory DIMMs in the system.

Applies to: LC1.5.0+

Prerequisites for script: none

Script: GetMemoryViews.win

- A) The Lifecycle Controller remote service must be in a “ready” state before executing any other WSMAN commands. The GetRSStatus() method or the GetRemoteServicesAPIStatus() method may be used depending on the version of the LC Management registered profile.
- B) GetMemoryViews(): ENUMERATE the *DCIM_MemoryView* class to view all instances. See section 2.2 for a definition of ENUMERATE .

The instance information of all available memory DIMMs will be returned.

21.3 Get the first memory’s information

Use the following procedure to get a single memory instance. The URI for getting particular instance information is deterministic (i.e the *InstanceID* will be unique for each instance).

Applies to: LC1.5.0+

Prerequisites for script: none

- Set desired instanceID by editing script

Script: GetMemoryView.win

- A) The Lifecycle Controller remote service must be in a “ready” state before executing any other WSMAN commands. The `GetRSStatus()` method or the `GetRemoteServicesAPIStatus()` method may be used depending on the version of the LC Management registered profile.
- B) `GetMemoryView()`: `GET` the `DCIM_MemoryView` instance using the `InstanceID=`
`DIMM.Socket.A1`. See Section 2.3 for a definition of `GET`.

The instance of `DCIM_MemoryView` that contains the information on the first memory DIMM will be returned.

22 PCI Device Profile Use Cases

22.1 Discovery of PCI Device profile support

Use the following procedure below to confirm the existence of PCI Device profile support.

Applies to: LC1.5.0+

Prerequisites for script: none

Script: `GetPCIDeviceProfile.win`

- A) The Lifecycle Controller remote service must be in a “ready” state before executing any other WSMAN commands. The `GetRSStatus()` method or the `GetRemoteServicesAPIStatus()` method may be used depending on the version of the LC Management registered profile.
- B) `GetLCRegisteredProfiles()`: `ENUMERATE` the `DCIM_LCRegisteredProfile` class to view all registered profiles. See section 2.2 for a definition of `ENUMERATE`.
- C) Search for “RegisteredName=PCI Device” and note its `instanceID` to use in step D)
- D) `GetLCRegisteredProfile()`: `GET` the `DCIM_LCRegisteredProfile` instance using the `InstanceID` from C). See Section 2.3 for a definition of `GET`.

Results for the `InstanceID` of `DCIM:PCIDevice:1.0.0` shown below. If no instance is returned, the profile is not supported.

NOTE: 12G example output shown below

```
DCIM_LCRegisteredProfile
  AdvertiseTypeDescriptions = WS-Identify
  AdvertiseTypeDescriptions = Interop Namespace
  AdvertiseTypes = 1
  AdvertiseTypes = 1
  InstanceID = DCIM:PCIDevice:1.0.0
  OtherRegisteredOrganization = DCIM
  ProfileRequireLicense = Remote Inventory
  ProfileRequireLicenseStatus = LICENSED
  RegisteredName = PCI Device
  RegisteredOrganization = 1
  RegisteredVersion = 1.0.0
```

23 Sensors Profile Use Cases

23.1 Discovery of Sensor profile support

There is currently not a registered Sensor Profile prior to LC2.0. However, the *CIM_Sensor* class has been implemented, which returns all the sensor views when enumerated.

Use the following procedure below to confirm the existence of Sensors profile support in LC2.0+.

Applies to: LC2+

Prerequisites for script: none

Script: GetSensorProfile.win

- A) The Lifecycle Controller remote service must be in a “ready” state before executing any other WSMAN commands.
GetRemoteServicesAPIStatus():
- B) GetLCRegisteredProfiles(): ENUMERATE the *DCIM_LCRegisteredProfile* class to view all registered profiles. See section 2.2 for a definition of ENUMERATE .
- C) Search for “RegisteredName=Sensors” and note its InstanceID to use in step D)
- D) GetLCRegisteredProfile(): GET the *DCIM_LCRegisteredProfile* instance using the *InstanceID* from C). See Section 2.3 for a definition of GET .

Results for the *InstanceID* of DCIM:Sensors:1.0.0 shown below. If no instance is returned, the profile is not supported.

NOTE: 12G example output shown below

```
DCIM_LCRegisteredProfile
  AdvertiseTypeDescriptions = WS-Identify
  AdvertiseTypeDescriptions = Interop Namespace
  AdvertiseTypes = 1
  AdvertiseTypes = 1
  InstanceID = DCIM:Sensors:1.0.0
  OtherRegisteredOrganization = DCIM
  ProfileRequireLicense = Device Monitoring
  ProfileRequireLicenseStatus = LICENSED
  RegisteredName = Sensors
  RegisteredOrganization = 1
  RegisteredVersion = 1.0.0
```

23.2 Inventory of sensor in system

Use the following procedure below to list the inventory of all sensors in the system.

Applies to: LC1.5.0+

Prerequisites for script: none

Script: GetSensorViews.win

- A) The Lifecycle Controller remote service must be in a “ready” state before executing any other WSMAN commands. The GetRSStatus() method or the GetRemoteServicesAPIStatus() method may be used depending on the version of the LC Management registered profile.
- B) GetSensorViews(): `ENUMERATE` the `CIM_Sensor` class to view all instances. See section 2.2 for a definition of `ENUMERATE` .

The instance information of all available sensors will be returned.

23.3 Sensor thresholds

Only sensors of Numeric type have thresholds (i.e. sensors of type `DCIM_PSNumericSensor` and `DCIM_NumericSensor`). Sensor instances of this type will indicate the supported thresholds in their `SupportedThresholds` property. They also indicate the settable ones through their `SettableThresholds` property. ‘Set’ operations can be performed to change the settable thresholds.

Applies to: LC1.5.0+

Prerequisites for script: Set thresholds by editing script

Script: SetSensorThresholds.win

- A) The Lifecycle Controller remote service must be in a “ready” state before executing any other WSMAN commands. The GetRSStatus() method or the GetRemoteServicesAPIStatus() method may be used depending on the version of the LC Management registered profile.
- B) GetSensorViews(): `ENUMERATE` the `CIM_Sensor` class to view all instances. Check the instance of either `DCIM_PSNumericSensor` and `DCIM_NumericSensor` to see if there are any settable thresholds
- C) SetSensorThreshold(): `SET` the `DCIM_PSNumericSensor` instance for temperature. Set the `LowerThresholdNonCritical` and `UpperThresholdNonCritical` values.

24 Base Server and Physical Asset Profile Use Cases

24.1 Discovery of Base Server and Physical Asset profile support

There is not an LC registered Base Server and Physical Asset Profile prior to LC2.0.

Use the following procedure below to confirm the existence of the Base Server and Physical Asset profile support in LC2.0+.

Applies to: LC2+

Prerequisites for script: none

Script: GetBaseServerAndPhysicalAssetProfile.win

- A) The Lifecycle Controller remote service must be in a “ready” state before executing any other WSMAN commands.
GetRemoteServicesAPIStatus();
- B) GetLCRegisteredProfiles(): ENUMERATE the *DCIM_LCRegisteredProfile* class to view all registered profiles. See section 2.2 for a definition of ENUMERATE .
- C) Search for “RegisteredName= Base Server and Physical Asset” and note its instanceID to use in step D)
- D) GetLCRegisteredProfile(): GET the *DCIM_LCRegisteredProfile* instance using the *InstanceID* from C). See Section 2.3 for a definition of GET .

Results for the *InstanceID* of DCIM:BaseServerandPhysicalAsset:1.0.0 shown below. If no instance is returned, the profile is not supported.

```
DCIM_LCRegisteredProfile
  AdvertiseTypeDescriptions = WS-Identify
  AdvertiseTypeDescriptions = Interop Namespace
  AdvertiseTypes = 1
  AdvertiseTypes = 1
  InstanceID = DCIM:BaseServerandPhysicalAsset:1.0.0
  OtherRegisteredOrganization = DCIM
  ProfileRequireLicense
  ProfileRequireLicenseStatus
  RegisteredName = Base Server and Physical Asset
  RegisteredOrganization = 1
  RegisteredVersion = 1.0.0
```

24.2 Discovery of Base Server and Physical Asset profile support [LC1.5.1]

There is not an LC registered Base Server and Physical Asset Profile prior to LC2.0. There are however, separate Base Server and Physical Asset profiles.

Use the following procedure below to confirm the existence of the Base Server profile and Physical Asset profile support prior to LC2.0.

Applies to: LC1.5.0, LC1.5.1

Prerequisites for script: none

Script: GetBaseServerAndPhysicalAssetProfilesLC151.win

- A) The Lifecycle Controller remote service must be in a “ready” state before executing any other WSMAN commands. The GetRSStatus() method or the GetRemoteServicesAPIStatus() method may be used depending on the version of the LC Management registered profile.
- B) GetCIMRegisteredProfiles(): ENUMERATE the *DCIM_RegisteredProfile* class to view all registered profiles. See section 2.2 for a definition of ENUMERATE .
- C) Search for “RegisteredName= Base Server” and note its instanceID to use in step E)
- D) Search for “RegisteredName= Physical Asset” and note its instanceID to use in step F)
- E) GetCIMRegisteredProfile(): GET the *DCIM_RegisteredProfile* instance using the *InstanceID* from C). See Section 2.3 for a definition of GET .

```
CIM_RegisteredProfile
  AdvertiseTypeDescriptions = WS-Identify
  AdvertiseTypes = 1
  Caption
  Description
  ElementName
  InstanceID = DCIM:CSRegisteredProfile:1
  OtherRegisteredOrganization
  RegisteredName = Base Server
  RegisteredOrganization = 2
  RegisteredVersion = 1.0.0
```

- F) GetCIMRegisteredProfile(): GET the *DCIM_RegisteredProfile* instance using the *InstanceID* from D). See Section 2.3 for a definition of GET .

```
CIM_RegisteredProfile
  AdvertiseTypeDescriptions = WS-Identify
  AdvertiseTypes = 1
  Caption
  Description
  ElementName
  InstanceID = DCIM:PhysicalAssetRegisteredProfile:1
  OtherRegisteredOrganization
  RegisteredName = Physical Asset
  RegisteredOrganization = 2
  RegisteredVersion = 1.0.0
```

24.3 List all CIM profiles

Use the following procedure below to list all CIM profiles supported on a system.

Applies to: LC1.3.0+

Prerequisites for script: none

Script: GetCIMRegisteredProfiles.win

- A) The Lifecycle Controller remote service must be in a “ready” state before executing any other WSMAN commands. The `GetRSStatus()` method or the `GetRemoteServicesAPIStatus()` method may be used depending on the version of the LC Management registered profile.
- B) `GetCIMRegisteredProfiles()`: `ENUMERATE` the `DCIM_RegisteredProfile` class to view all registered profiles. See section 2.2 for a definition of `ENUMERATE` .

25 Video Profile Use Cases

25.1 Discovery of Video profile support

Use the following procedure below to confirm the existence of Video profile support.

Applies to: LC1.5.0+

Prerequisites for script: none

Script: `GetVideoProfile.win`

- A) The Lifecycle Controller remote service must be in a “ready” state before executing any other WSMAN commands. The `GetRSStatus()` method or the `GetRemoteServicesAPIStatus()` method may be used depending on the version of the LC Management registered profile.
- B) `GetLCRegisteredProfiles()`: `ENUMERATE` the `DCIM_LCRegisteredProfile` class to view all registered profiles. See section 2.2 for a definition of `ENUMERATE` .
- C) Search for “RegisteredName=Video” and note its `InstanceID` to use in step D)
- D) `GetLCRegisteredProfile()`: `GET` the `DCIM_LCRegisteredProfile` instance using the `InstanceID` from C). See Section 2.3 for a definition of `GET` .

Results for the `InstanceID` of `DCIM:Video:1.0.0` shown below. If no instance is returned, the profile is not supported.

```
DCIM_LCRegisteredProfile
  AdvertiseTypeDescriptions = WS-Identify
  AdvertiseTypeDescriptions = Interop Namespace
  AdvertiseTypes = 1
  AdvertiseTypes = 1
  InstanceID = DCIM:Video:1.0.0
  OtherRegisteredOrganization = DCIM
  ProfileRequireLicense = Remote Inventory
  ProfileRequireLicenseStatus = LICENSED
  RegisteredName = Video
  RegisteredOrganization = 1
  RegisteredVersion = 1.0.0
```

25.2 Inventory of video in system

Use the following procedure below to list the inventory of all video in the system.

Applies to: LC1.5.0+

Prerequisites for script: none

Script: GetVideoViews.win

- A) The Lifecycle Controller remote service must be in a “ready” state before executing any other WSMAN commands. The GetRSStatus() method or the GetRemoteServicesAPIStatus() method may be used depending on the version of the LC Management registered profile.
- B) GetVideoViews(): ENUMERATE the *DCIM_VideoView* class to view all instances. See section 2.2 for a definition of ENUMERATE .

The instance information of all available video components will be returned.

25.3 Get the first video instance’s information

Use the following procedure to get a single video instance. The URI for getting particular instance information is deterministic (i.e the *InstanceID* will be unique for each instance).

Applies to: LC1.5.0+

Prerequisites for script:

- Set desired instanceID by editing script

Script: GetVideoView.win

- A) The Lifecycle Controller remote service must be in a “ready” state before executing any other WSMAN commands. The GetRSStatus() method or the GetRemoteServicesAPIStatus() method may be used depending on the version of the LC Management registered profile.
- B) GetVideoView(): GET the *DCIM_VideoView* instance using the *InstanceID=Video.Embedded.1-1*. See Section 2.3 for a definition of GET .

The instance of *DCIM_VideoView* that contains the information will be returned.

26 License Management Profile Use Cases

26.1 Discovery of License Management profile support

Use the following procedure below to confirm the existence of License Management profile support.

Applies to: LC2+

Prerequisites for script: none

Script: GetLicenseManagementProfile.win

- A) The Lifecycle Controller remote service must be in a “ready” state before executing any other WSMAN commands.
GetRemoteServicesAPIStatus();
- B) GetLCRegisteredProfiles(): ENUMERATE the *DCIM_LCRegisteredProfile* class to view all registered profiles. See section 2.2 for a definition of ENUMERATE .
- C) Search for “RegisteredName= License Management” and note its instanceID to use in step D)
- D) GetLCRegisteredProfile(): GET the *DCIM_LCRegisteredProfile* instance using the *InstanceID* from C). See Section 2.3 for a definition of GET .

Results for the *InstanceID* of DCIM:LicenseManagement:1.0.0 shown below. If no instance is returned, the profile is not supported.

```
DCIM_LCRegisteredProfile
  AdvertiseTypeDescriptions = WS-Identify
  AdvertiseTypeDescriptions = Interop Namespace
  AdvertiseTypes = 1
  AdvertiseTypes = 1
  InstanceID = DCIM:LicenseManagement:1.0.0
  OtherRegisteredOrganization = DCIM
  ProfileRequireLicense = Licensing Management
  ProfileRequireLicenseStatus = LICENSED
  RegisteredName = License Management
  RegisteredOrganization = 1
  RegisteredVersion = 1.0.0
```

27 Power Supply Profile Use Cases

27.1 Discovery of Power Supply profile support

Use the following procedure below to confirm the existence of Power Supply profile support.

Applies to: LC1.5.0+

Prerequisites for script: none

Script: GetPowerSupplyProfile.win

- A) The Lifecycle Controller remote service must be in a “ready” state before executing any other WSMAN commands. The GetRSStatus() method or the GetRemoteServicesAPIStatus() method may be used depending on the version of the LC Management registered profile.
- B) GetLCRegisteredProfiles(): ENUMERATE the *DCIM_LCRegisteredProfile* class to view all registered profiles. See section 2.2 for a definition of ENUMERATE .
- C) Search for “RegisteredName=Power Supply” and note its instanceID to use in step D)
- D) GetLCRegisteredProfile(): GET the *DCIM_LCRegisteredProfile* instance using the *InstanceID* from C). See Section 2.3 for a definition of GET .

Results for the *InstanceID* of DCIM:PowerSupply:2.0.0 shown below. If no instance is returned, the profile is not supported.

```
DCIM_LCRegisteredProfile
  AdvertiseTypeDescriptions = WS-Identify
  AdvertiseTypeDescriptions = Interop Namespace
  AdvertiseTypes = 1
  AdvertiseTypes = 1
  InstanceID = DCIM:PowerSupply:2.0.0
  OtherRegisteredOrganization = DCIM
  ProfileRequireLicense = Remote Inventory
  ProfileRequireLicenseStatus = LICENSED
  RegisteredName = Power Supply
  RegisteredOrganization = 1
  RegisteredVersion = 2.1.0
```

27.2 Inventory of power supplies in system

Use the following procedure below to list the inventory of all power supplies in the system.

Applies to: LC1.5.0+

Prerequisites for script: none

Script: GetPowerSupplyViews.win

- A) The Lifecycle Controller remote service must be in a “ready” state before executing any other WSMAN commands. The GetRSStatus() method or the GetRemoteServicesAPIStatus() method may be used depending on the version of the LC Management registered profile.
- B) GetFanViews(): ENUMERATE the *DCIM_PowerSupplyView* class to view all instances. See section 2.2 for a definition of ENUMERATE .

The instance information of all available power supplies will be returned.

27.3 Get the first power supply's information

Use the following procedure to get a single power supply instance. The URI for getting particular instance information is deterministic (i.e the *InstanceID* will be unique for each instance).

Applies to: LC1.5.0+

Prerequisites for script:

- Set desired instanceID by editing script

Script: GetPowerSupplyView.win

- A) The Lifecycle Controller remote service must be in a “ready” state before executing any other WSMAN commands. The GetRSStatus() method or the GetRemoteServicesAPIStatus() method may be used depending on the version of the LC Management registered profile.
- B) GetPowerSupplyView(): GET the *DCIM_PowerSupplyView* instance using the *InstanceID=PSU.Slot.1*. See Section 2.3 for a definition of GET .

The instance of *DCIM_PowerSupplyView* that contains the information on the first power supply will be returned.

27.4 Get MAC information

This workflow enumerates *DCIM_SystemView* and invokes GetMACInfo.

Applies to: LC1.5.0

Prerequisites for script: none

Script: CollectBlades.win

- A) The Lifecycle Controller remote service must be in a “ready” state before executing any other WSMAN commands. The GetRSStatus() method or the GetRemoteServicesAPIStatus() method may be used depending on the version of the LC Management registered profile.
- B) GetSystemViews(): ENUMERATE the *DCIM_SystemView* class. See section 2.2 for a definition of ENUMERATE .
- C) GetHostMACInfo(): Invoke GetHostMACInfo [ReturnValue=0]

27.5 Get blade power

This workflow enumerates *DCIM_AssociatedPowerManagementService* class.

Applies to: LC1.5.0

Prerequisites for script: none

Script: GetBladePower.win

- A) The Lifecycle Controller remote service must be in a “ready” state before executing any other WSMAN commands. The *GetRSStatus()* method or the *GetRemoteServicesAPIStatus()* method may be used depending on the version of the LC Management registered profile.
- B) *GetAssociatedPowerManagementService()*: *ENUMERATE* the *CIM_AssociatedPowerManagementService* class. See section 2.2 for a definition of *ENUMERATE* .

28 System Info Profile Use Cases

28.1 Discovery of System Info profile support

Use the following procedure below to confirm the existence of System Info profile support.

Applies to: LC1.5.0+

Prerequisites for script: none

Script: GetSystemInfoProfile.win

- A) The Lifecycle Controller remote service must be in a “ready” state before executing any other WSMAN commands. The *GetRSStatus()* method or the *GetRemoteServicesAPIStatus()* method may be used depending on the version of the LC Management registered profile.
- B) *GetLCRegisteredProfiles()*: *ENUMERATE* the *DCIM_LCRegisteredProfile* class to view all registered profiles. See section 2.2 for a definition of *ENUMERATE* .
- C) Search for “RegisteredName=System Info” and note its *instanceID* to use in step D)
- D) *GetLCRegisteredProfile()*: *GET* the *DCIM_LCRegisteredProfile* instance using the *InstanceID* from C). See Section 2.3 for a definition of *GET* .

Results for the *InstanceID* of *DCIM:SystemInfo:1.0.0* shown below. If no instance is returned, the profile is not supported.

```
DCIM_LCRegisteredProfile
  AdvertiseTypeDescriptions = WS-Identify
  AdvertiseTypeDescriptions = Interop Namespace
  AdvertiseTypes = 1
  AdvertiseTypes = 1
  InstanceID = DCIM:SystemInfo:1.0.0
```

OtherRegisteredOrganization = DCIM
ProfileRequireLicense = Power Budget
ProfileRequireLicense = Remote Firmware Configuration
ProfileRequireLicenseStatus = LICENSED
ProfileRequireLicenseStatus = LICENSED
RegisteredName = System Info
RegisteredOrganization = 1
RegisteredVersion = 1.2.0

28.2 Inventory of system info view

Use the following procedure below to list the inventory of all system info in the system.

Applies to: LC1.5.0+

Prerequisites for script: none

Script: GetSystemInfoViews.win

- GetSystemViews(): ENUMERATE the *DCIM_SystemView* class to view all instances. See section 2.2 for a definition of ENUMERATE .

The instance information of all available system info will be returned.

28.3 Get the first system info view's information

Use the following procedure to get a single system info instance. The URI for getting particular instance information is deterministic (i.e the *InstanceID* will be unique for each instance).

Applies to: LC1.5.0+

Prerequisites for script:

- Set desired instanceID by editing script

Script: GetSystemInfoView.win

- A) The Lifecycle Controller remote service must be in a “ready” state before executing any other WSMAN commands. The GetRSStatus() method or the GetRemoteServicesAPIStatus() method may be used depending on the version of the LC Management registered profile.
- B) GetSystemView(): GET the *DCIM_SystemView* instance using the *InstanceID=System.Embedded.1*. See Section 2.3 for a definition of GET .

The instance of *DCIM_SystemView* that contains the information on the first system info will be returned.

28.4 Inventory of all system attributes in system

Use the following procedure below to list the inventory of all system attributes in the system using the *DCIM_SystemAttribute* class. The instances from the following classes will be returned: *DCIM_SystemEnumeration*, *DCIM_SystemInteger*, *DCIM_SystemString*.

Applies to: LC2+

Prerequisites for script: none

Script: *GetSystemAttributes.win*

- A) The Lifecycle Controller remote service must be in a “ready” state before executing any other WSMAN commands.

`GetRemoteServicesAPIStatus():`

- B) `GetSystemAttributes():` `ENUMERATE` the *DCIM_SystemAttribute* class to view all instances of the attributes: *DCIM_SystemEnumeration*, *DCIM_SystemInteger*, and *DCIM_SystemString*. See section 2.2 for a definition of `ENUMERATE` .

The instance information of all available system attributes will be returned.

28.5 Get a single system string attribute

Use the following procedure below to get a single system attribute in the system.

Applies to: LC2+

Prerequisites for script: Set desired *instanceID* by editing script

Script: *GetSystemString.win*

- A) The Lifecycle Controller remote service must be in a “ready” state before executing any other WSMAN commands.

`GetRemoteServicesAPIStatus():`

- B) `GetSystemString():` `GET` the instance using the desired class’s *InstanceID*. See Section 2.3 for a definition of `GET` .

The instance that contains the information on the attribute will be returned.

28.6 Setting and applying system attributes

The following procedure sets a system attribute and applies the new configuration.

Applies to: LC2+

Prerequisites for script: Set desired values by editing script

Script: SetSystemAttribute.win

- A) The Lifecycle Controller remote service must be in a “ready” state before executing any other WSMAN commands.

GetRemoteServicesAPIStatus():

- B) GetSystemAttributes(): ENUMERATE the *DCIM_SystemAttribute* class to view all instances of the attributes from the following classes: *DCIM_SystemEnumeration*, *DCIM_SystemInteger*, and *DCIM_SystemString*. See section 2.2 for a definition of ENUMERATE .

- C) Confirm correct FQDD and that the *IsReadOnly* field is set to false

- D) SetSystemAttribute(): Invoke the SetSystemAttribute() method on the *DCIM_SystemManagement* class. The method will set the PendingValue property of the system attributes to the specified value passed in from the input parameters. [Return value = 0]

NOTE: Use SetSystemAttribute() to set one attribute and SetSystemAttributes() to set multiple attributes. Both methods take the same input parameters but the types of input parameter are different. SetSystemAttributes() uses string input and SetSystemAttributs() uses arrays of strings for input.

- E) CreateSystemConfigJob(): Apply the pending values, pass ScheduledStartTime of TIME_NOW, to invoke the reboot to apply the new attribute values immediately.

NOTE: This method also allows the user to schedule when to apply the attribute value change. If the schedule is TIME_NOW, the PendingValue will be applied to the CurrentValue of the attribute immediately. There is no reboot required for setting system attributes as indicated in the output parameter RebootRequired.

- F) Poll jobstatus for Completed: GET the *InstanceID* of from E). See section 2.3 for a definition of GET .

- G) Repeat C) to confirm successful execution of the method by examining PendingValue property of the attributes that were set by this step.

28.7 Apply pending system attribute values

See the previous section, Setting and Applying System Attributes, for a use case for this method.

28.8 Delete pending system attribute values

Use the following procedure below to delete pending configurations/values set by the setAttribute(s) method.

Applies to: LC1.5.0+

Prerequisites for script: none

Script: DeletePendingSystemInfoConfiguration.win

- A) The Lifecycle Controller remote service must be in a “ready” state before executing any other WSMAN commands. The GetRSStatus() method or the GetRemoteServicesAPIStatus() method may be used depending on the version of the LC Management registered profile.
- B) GetSystemViews(): ENUMERATE the *DCIM_SystemAttributes* class to view all available FQDDs. See section 2.2 for a definition of ENUMERATE .
- C) DeletePendingSystemConfiguration(): Invoke the DeletePendingSystemConfiguration() method on the *DCIM_SystemManagementService* class to delete pending configurations on ALL system attributes.

A return message of “No pending data present to delete” indicates that there is no pending configuration to delete for the respective FQDD.

29 Software Inventory Profile Use Cases

29.1 Instance diagram

Figure 4. Software Inventory: Instance Diagram

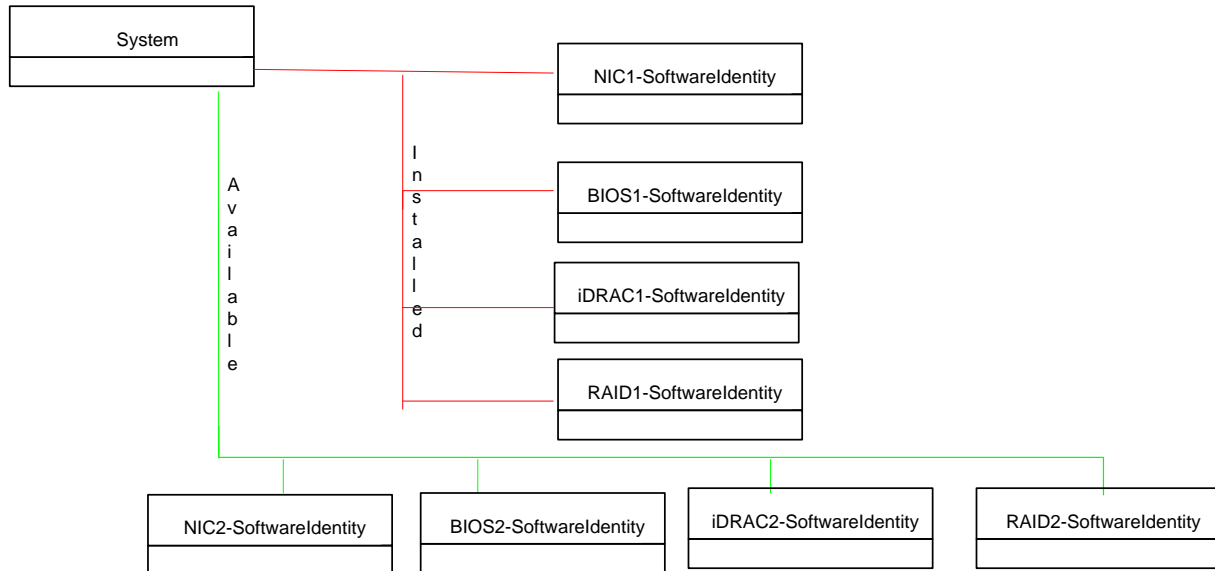

29.2 Discovery of Software Inventory profile support

Use the following procedure below to confirm the existence of Software Inventory profile support.

Applies to: LC1.4.0+

Prerequisites for script: none

Script: GetSWInventoryProfile.win

- A) The Lifecycle Controller remote service must be in a “ready” state before executing any other WSMAN commands. The GetRSStatus() method or the GetRemoteServicesAPIStatus() method may be used depending on the version of the LC Management registered profile.
- B) GetLCRegisteredProfiles(): ENUMERATE the *DCIM_LCRegisteredProfile* class to view all registered profiles. See section 2.2 for a definition of ENUMERATE .
- C) Search for “RegisteredName = Software Inventory” and note its instanceID to use in step D)
- D) GetLCRegisteredProfile(): GET the *DCIM_LCRegisteredProfile* instance using the *InstanceID* from C). See Section 2.3 for a definition of GET .

Results for the *InstanceID* of DCIM:SoftwareInventory:1.0.0 shown below. If no instance is returned, the profile is not supported.

```

DCIM_LCRegisteredProfile
  AdvertiseTypeDescriptions = WS-Identify
  AdvertiseTypeDescriptions = Interop Namespace
  
```



```
AdvertiseTypes = 1
AdvertiseTypes = 1
InstanceID = DCIM:SoftwareInventory:1.0.0
OtherRegisteredOrganization = DCIM
ProfileRequireLicense = Remote Inventory
ProfileRequireLicenseStatus = LICENSED
RegisteredName = Software Inventory
RegisteredOrganization = 1
RegisteredVersion = 1.1.0
```

29.3 Inventory of software in system

Use the following procedure below to list the inventory of all software in the system.

Applies to: LC1.4.0+

Prerequisites for script: none

Script: GetSoftwareInventoryViews.win

- A) The Lifecycle Controller remote service must be in a “ready” state before executing any other WSMAN commands. The GetRSStatus() method or the GetRemoteServicesAPIStatus() method may be used depending on the version of the LC Management registered profile.
- B) GetSoftwareIdentities(): ENUMERATE the *DCIM_SoftwareIdentity* class to view all instances. See section 2.2 for a definition of ENUMERATE .

The instance information of all available software will be returned.

29.4 Get the installed BIOS firmware inventory

Use the following procedure to get the BIOS installed software instance. The URI for getting particular instance information is deterministic (i.e the *InstanceID* will be unique for each instance).

Applies to: LC1.4.0+

Prerequisites for script: none

Script: GetInstalledBIOSView.win

- A) The Lifecycle Controller remote service must be in a “ready” state before executing any other WSMAN commands. The GetRSStatus() method or the GetRemoteServicesAPIStatus() method may be used depending on the version of the LC Management registered profile.
- B) GetSoftwareIdentities(): ENUMERATE the *DCIM_SoftwareIdentity* class to view all instances. See section 2.2 for a definition of ENUMERATE .

Choose the Software Identity instance with ElementName="BIOS" and Status="Installed" to use in C)

- C) GetSoftwareIdentity(): GET the *DCIM_SoftwareIdentity* instance from C). See Section 2.3 for a definition of GET .

The instance of the installed BIOS that contains the information will be returned.

29.5 Get the available iDRAC firmware inventory

Use the following procedure to get the available iDRAC software instance. The URI for getting particular instance information is deterministic (i.e the *InstanceID* will be unique for each instance).

Applies to: LC1.4.0+

Prerequisites for script: none

Script: GetAvailableiDRACView.win

- A) The Lifecycle Controller remote service must be in a "ready" state before executing any other WSMAN commands. The GetRSStatus() method or the GetRemoteServicesAPIStatus() method may be used depending on the version of the LC Management registered profile.
- B) GetSoftwareIdentities(): ENUMERATE the *DCIM_SoftwareIdentity* class to view all instances. See section 2.2 for a definition of ENUMERATE .

[Prior to LC2] Choose the Software Identity instance with ElementName="iDRAC6" and Status="Available" to use in C)

[LC2] Choose the Software Identity instance with ElementName=" Integrated Dell Remote Access Controller" and Status="Available" to use in C)

- C) GetSoftwareIdentity(): GET the *DCIM_SoftwareIdentity* instance from C). See Section 2.3 for a definition of GET .

The instance of the available iDRAC that contains the information will be returned.

30 Simple Identity Management Profile Use Cases

30.1 Discovery of Simple Identity Management profile support

There is currently not a registered Simple Identity Management Profile prior to LC2. Use the following procedure below to confirm the existence of Simple Identity Management profile support.

Applies to: LC2+

Prerequisites for script: none

Script: GetSimpleIdentityMGMTProfile.win

- A) The Lifecycle Controller remote service must be in a “ready” state before executing any other WSMAN commands.
GetRemoteServicesAPIStatus();
- B) GetLCRegisteredProfiles(): ENUMERATE the *DCIM_LCRegisteredProfile* class to view all registered profiles. See section 2.2 for a definition of ENUMERATE .
- C) Search for “RegisteredName = Simple Identity Management” and note its instanceID to use in step D)
- D) GetLCRegisteredProfile(): GET the *DCIM_LCRegisteredProfile* instance using the *InstanceID* from C). See Section 2.3 for a definition of GET .

Results for the *InstanceID* of DCIM:SimpleIdentityManagement:1.0.0 shown below. If no instance is returned, the profile is not supported.

```
DCIM_LCRegisteredProfile
  AdvertiseTypeDescriptions = WS-Identify
  AdvertiseTypeDescriptions = Interop Namespace
  AdvertiseTypes = 1
  AdvertiseTypes = 1
  InstanceID = DCIM:SimpleIdentityManagement:1.0.0
  OtherRegisteredOrganization = DCIM
  ProfileRequireLicense
  ProfileRequireLicenseStatus
  RegisteredName = Simple Identity Management
  RegisteredOrganization = 1
  RegisteredVersion = 1.0.0
```

31 LC Management Profile Use Cases

31.1 Discovery of LC Management profile support

Use the following procedure below to confirm the existence of LC Management profile support.

Applies to: LC1.5.0+

Prerequisites for script: none

Script: GetLCManagementProfile.win

- A) The Lifecycle Controller remote service must be in a “ready” state before executing any other WSMAN commands. The GetRSStatus() method or the GetRemoteServicesAPIStatus() method may be used depending on the version of the LC Management registered profile.
- B) GetLCRegisteredProfiles(): ENUMERATE the *DCIM_LCRegisteredProfile* class to view all registered profiles. See section 2.2 for a definition of ENUMERATE .
- C) Search for “RegisteredName = LC Management” and note its instanceID to use in step D)
- D) GetLCRegisteredProfile(): GET the *DCIM_LCRegisteredProfile* instance using the *InstanceID* from C). See Section 2.3 for a definition of GET .

Results for the *InstanceID* of DCIM:LCManagement:1.1.0 shown below. If no instance is returned, the profile is not supported.

```
DCIM_LCRegisteredProfile
  AdvertiseTypeDescriptions = WS-Identify
  AdvertiseTypeDescriptions = Interop Namespace
  AdvertiseTypes = 1
  AdvertiseTypes = 1
  InstanceID = DCIM:LCManagement:1.1.0
  OtherRegisteredOrganization = DCIM
  ProfileRequireLicense = Auto Discovery
  ProfileRequireLicense = Part Replacement
  ProfileRequireLicense = Remote Firmware Configuration
  ProfileRequireLicense = Remote Inventory Export
  ProfileRequireLicense = Server Profile Export and Import
  ProfileRequireLicenseStatus = LICENSED
  ProfileRequireLicenseStatus = LICENSED
  ProfileRequireLicenseStatus = LICENSED
  ProfileRequireLicenseStatus = LICENSED
  ProfileRequireLicenseStatus = LICENSED
  RegisteredName = LC Management
  RegisteredOrganization = 1
  RegisteredVersion = 1.4.0
```

31.2 Inventory of LC Management attributes in system

Use the following procedure below to view all available LC attributes and possible values in the system.

Applies to: LC1.5.0+

Prerequisites for script: none

Script: GetAllLCAttributes.win

- A) The Lifecycle Controller remote service must be in a “ready” state before executing any other WSMAN commands. The `GetRSStatus()` method or the `GetRemoteServicesAPIStatus()` method may be used depending on the version of the LC Management registered profile.
- B) `GetLCEnumerations()`: `ENUMERATE` the `DCIM_LCEnumeration` class to view all instances. See section 2.2 for a definition of `ENUMERATE` .
- C) `GetLCStrings()`: `ENUMERATE` the `DCIM_LCString` class to view all instances. See section 2.2 for a definition of `ENUMERATE` .

The instance information of all available LC Management attributes will be returned

31.3 Check and enable (or disable) Collect System Inventory on Restart (CSIOR)

This workflow first checks whether CSIOR is enabled (or disabled), if it is not, then it is set to Enabled (or Disabled). While setting the attribute, it checks both the pending and final values.

Applies to: LC1.4.0+

Prerequisites for script: none

Script: `EnableCSIOR.win` (or `DisableCSIOR.win`)

- A) The Lifecycle Controller remote service must be in a “ready” state before executing any other WSMAN commands. The `GetRSStatus()` method or the `GetRemoteServicesAPIStatus()` method may be used depending on the version of the LC Management registered profile.
- B) `GetLCEnumerations()`: `ENUMERATE` the `DCIM_LCEnumeration` class and find the current value of CSIOR by searching for “Attribute=Collect System Inventory on Restart”. See section 2.2 for a definition of `ENUMERATE` .
- C) `SetLCAttribute()`: Set the CSIOR attribute if it is Disabled (or Enabled)
- D) `GetLCEnumerations()`: `ENUMERATE` the `DCIM_LCEnumeration` class to ensure the pending value of CSIOR is Enabled (or Enabled). See section 2.2 for a definition of `ENUMERATE` .
- E) `CreateLCConfigJob()`: Apply step C) [`ReturnValue=4096`]
- F) Poll jobstatus for Completed: `GET` the `InstanceID` of from E). See section 2.3 for a definition of `GET` .
NOTE: `LC1.x` polls for ‘COMPLETED’, while `LC2` polls for ‘Completed’
- G) `GetLCEnumerations()`: `ENUMERATE` the `DCIM_LCEnumeration` class to ensure the new value of CSIOR is Enabled (or Disabled). See section 2.2 for a definition of `ENUMERATE` .

31.4 Check version of Lifecycle Controller (LC)

This workflow enumerates the *DCIM_SystemView* class and searches for the *LifecycleControllerVersion* attribute to determine the LC version on the system.

Applies to: LC1.5.1+

Prerequisites for script: none

Script: CheckLCVersion.win

- A) *GetSystemViews()*: ENUMERATE the *DCIM_SystemView* class. See section 2.2 for a definition of ENUMERATE .
- B) Search for the *LifecycleControllerVersion* attribute, the corresponding value of this attribute is the version of LC.

31.5 Get “Part Firmware Update” attribute

Use the following procedure to get the Part Firmware Update attribute. The URI for getting particular instance information is deterministic (i.e the *InstanceID* will be unique for each instance)

Applies to: LC1.4.0+

Prerequisites for script: none

Script: GetPartFWUpdateAttribute.win

- A) The Lifecycle Controller remote service must be in a “ready” state before executing any other WSMAN commands. The *GetRSStatus()* method or the *GetRemoteServicesAPIStatus()* method may be used depending on the version of the LC Management registered profile.
- B) *GetLCEnumerations()*: ENUMERATE the *DCIM_LCEnumeration* class to new view all available instances. See section 2.2 for a definition of ENUMERATE .
- C) Search for “AttributeName = Part Firmware Update” and note its *instanceID* to use in step D)
- D) *GetLCEnumeration ()*: GET the *DCIM_LCEnumeration* instance using the *InstanceID* from C). See Section 2.3 for a definition of GET .

The instance containing the attribute will be returned.

31.6 Check vFlash license enablement

Use the following procedure to get the Part Firmware Update attribute. The URI for getting particular instance information is deterministic (i.e the *InstanceID* will be unique for each instance)

Applies to: LC1.5.0+

Prerequisites for script: none

Script: CheckVFlashLicense.win

- A) The Lifecycle Controller remote service must be in a “ready” state before executing any other WSMAN commands. The GetRSStatus() method or the GetRemoteServicesAPIStatus() method may be used depending on the version of the LC Management registered profile.
- B) GetLCEnumerations(): ENUMERATE the *DCIM_LCEnumeration* class to new view all available instances. See section 2.2 for a definition of ENUMERATE .
- C) Search for “AttributeName =Licensed” and note its instanceID to use in step D)
- D) GetLCRegisteredProfile(): GET the *DCIM_LCRegisteredProfile* instance using the *InstanceID* from C). See Section 2.3 for a definition of GET .

Check the CurrentValue parameter to determine if the system is licensed.

```
DCIM_LCEnumeration
AttributeName = Licensed
CurrentValue = Yes
DefaultValue = No
ElementName = LC.emb.1
InstanceID = LifecycleController.Embedded.1#LCAttributes.1#Licensed
IsReadOnly = true
PendingValue
PossibleValues = No
PossibleValues = Yes
```

31.7 Set configuration to “Auto Discovery Factory Defaults”

Use the following procedure to set the Auto Discovery configuration to factory defaults.

Applies to: LC1.5.0+

Prerequisites for script: none

Script: SetAutoDiscoveryFactoryDefaults.win

- A) The Lifecycle Controller remote service must be in a “ready” state before executing any other WSMAN commands. The GetRSStatus() method or the GetRemoteServicesAPIStatus() method may be used depending on the version of the LC Management registered profile.
- B) GetLCEnumerations(): ENUMERATE the *DCIM_LCEnumeration* class to new view all available instances. See section 2.2 for a definition of ENUMERATE .
- C) Search for “AttributeName = Discovery Factory Defaults” and note its instanceID to use in step D)

D) `GetLCRegisteredProfile()`: GET the *DCIM_LCRegisteredProfile* instance using the *InstanceID* from C). See Section 2.3 for a definition of GET.

The instance containing the attribute will be returned. If the *CurrentValue* parameter is “on”, Auto Discovery Factory Defaults is already on, proceed to end.

E) `ReinitiateDHS()`: Invoke method to set Auto Discovery values

F) Repeat step D) to confirm *CurrentValue* is now ‘on’

31.8 Clear provisioning server

Use the following procedure to clear the provisioning server name.

Applies to: LC1.5.0+

Prerequisites for script: none

Script: `ClearProvisioningServer.win`

A) The Lifecycle Controller remote service must be in a “ready” state before executing any other WSMAN commands. The `GetRSStatus()` method or the `GetRemoteServicesAPIStatus()` method may be used depending on the version of the LC Management registered profile.

B) `ClearProvisioningServer()`: Invokes the `ClearProvisioningServer` method

31.9 Replace auto discovery public key

Refer to Web Service Interface Guide section 12.6

31.10 Replace auto discovery client certificate, private key and password

Refer to Web Service Interface Guide section 12.7.

31.11 Delete auto discovery public key

Refer to Web Service Interface Guide section 12.11.

31.12 Delete auto discovery client certificat, private key and password

Refer to Web Service Interface Guide section 12.8.

31.13 Replace iDRAC web server client certificate and private key

Refer to Web Service Interface Guide section 12.10

31.14 Replace iDRAC web server public certificate

Refer to Web Service Interface Guide section 12.9

31.15 Insert comment into Lifecycle log

Use the following procedure to insert a comment into the LC log.

Applies to: LC1.5.0+

Prerequisites for script: Insert desired comment by editing script

Script: InsertCommentInLCLog.win

- A) The Lifecycle Controller remote service must be in a “ready” state before executing any other WSMAN commands. The GetRSStatus() method or the GetRemoteServicesAPIStatus() method may be used depending on the version of the LC Management registered profile.
- B) InsertCommentInLCLog(): Invokes the InsertCommentInLCLog method

31.16 Export and view the content of the Lifecycle log

See section 3.16 of this document.

31.17 Export and view the current hardware inventory

This workflow exports the hardware inventory to either an NFS or CIFS share. Approximate time for completion on an 11G system is 5 minutes depending on the system configuration.

Applies to: LC1.5.0+

Prerequisites for script:

- Set script variables by editing script

Script: ExportHWInventory.win

A) The Lifecycle Controller remote service must be in a “ready” state before executing any other WSMAN commands. The GetRSStatus() method or the GetRemoteServicesAPIStatus() method may be used depending on the version of the LC Management registered profile.

B) ExportHWInventory(): Invokes the export operation [ReturnValue=4096]

NOTE: The user must set applicable IP address, username, password, filename, and workgroup of the network share.

C) Poll jobstatus for Completed: GET the *InstanceID* of from D). See section 2.3 for a definition of GET .

31.18 Export and view the hardware inventory as shipped from the factory

This workflow exports the factory configuration inventory to either an NFS or CIFS share. Approximate time for completion on an 12G system is 5 minutes depending on the system configuration.

Applies to: LC1.5.0+

Prerequisites for script:

- Set script variables by editing script

Script: ExportFactoryConfiguration.win

A) The Lifecycle Controller remote service must be in a “ready” state before executing any other WSMAN commands. The GetRSStatus() method or the GetRemoteServicesAPIStatus() method may be used depending on the version of the LC Management registered profile.

B) ExportFactoryConfiguration(): Invokes the export operation [ReturnValue=4096]

NOTE: The user must set applicable IP address, username, password, filename, and workgroup of the network share.

C) Poll jobstatus for Completed: GET the *InstanceID* of from D). See section 2.3 for a definition of GET .

32 OS Deployment Profile Use Cases

32.1 Discovery of OS Deployment profile support

Use the following procedure below to confirm the existence of OS Deployment profile support.

Applies to: LC1.3.0+

Prerequisites for script: none

Script: GetOSDProfile.win

- A) The Lifecycle Controller remote service must be in a “ready” state before executing any other WSMAN commands. The GetRSStatus() method or the GetRemoteServicesAPIStatus() method may be used depending on the version of the LC Management registered profile.
- B) GetLCRegisteredProfiles(): ENUMERATE the *DCIM_LCRegisteredProfile* class to view all registered profiles. See section 2.2 for a definition of ENUMERATE .
- C) Search for “RegisteredName= OS Deployment” and note its instanceID to use in step D)
- D) GetLCRegisteredProfile(): GET the *DCIM_LCRegisteredProfile* instance using the *InstanceID* from C). See Section 2.3 for a definition of GET .

Results for the *InstanceID* of DCIM:OSDeployment:1.1.0 shown below. If no instance is returned, the profile is not supported.

```
DCIM_LCRegisteredProfile
  AdvertiseTypeDescriptions = WS-Identify
  AdvertiseTypeDescriptions = Interop Namespace
  AdvertiseTypes = 1
  AdvertiseTypes = 1
  InstanceID = DCIM:OSDeployment:1.1.0
  OtherRegisteredOrganization = DCIM
  ProfileRequireLicense = Remote Operating System Deployment
  ProfileRequireLicenseStatus = LICENSED
  RegisteredName = OS Deployment
  RegisteredOrganization = 1
  RegisteredVersion = 1.4.0
```

32.2 Unpack and attach drivers

See section 4.3 Boot to networkISO and 4.4 Boot to ISO from vFlash for a comprehensive example.

32.3 Connect and attach network ISO image

See section 4.3 Boot to networkISO and 4.4 Boot to ISO from vFlash for a comprehensive example.

32.4 Disconnect and detach network ISO image

See section 4.3 Boot to networkISO and 4.4 Boot to ISO from vFlash for a comprehensive example.

32.5 Get ISO image connection status

See section 4.3 Boot to networkISO and 4.4 Boot to ISO from vFlash for a comprehensive example. GetNetworkISOImageConnectionInfo() can be invoked from within either of the aforementioned scripts to obtain the status.

32.6 One time ISO boot skip

Following sequence of CIM Operations shall be used to skip ISO boot once. The SkipISOImageBoot() method allows the BIOS to skip booting to the ISO once and boot normally (boot to the first device in boot list).

Applies to: LC1.5.0+

Prerequisites for script: none

Script: SkipISOImageBoot.win

A) The Lifecycle Controller remote service must be in a “ready” state before executing any other WSMAN commands. The GetRSStatus() method or the GetRemoteServicesAPIStatus() method may be used depending on the version of the LC Management registered profile.

NOTE: GetRemoteServicesAPIStatus() will return “not ready” if drivers or an ISO is already attached.

B) SkipISOImageBoot(): Invoke the method, successful return value is 0

32.7 Remote File Share (RFS) use cases

32.7.1 Connect and Attach Network ISO Image as a USB CD-ROM device via RFS USB end point.

Following sequence of CIM Operations shall be used to connect and attach network ISO Image from the specified network share to the host server as a USB CD-ROM device via RFS USB end point.

Applies to: LC2+

Prerequisites for script: set network parameters by editing script

Script: ConnectRFSISOImage.win

NOTE: Check of Lifecycle Controller (LC) remote service state, via `GetRemoteServicesAPIStatus()`, is not required since ISO is connected using RFS USB endpoint and LC status is not relevant.

- A) Confirm RFS (remote file share) is NOT in Detach mode. iDRAC attribute `AttachMode` value needs to be changed to `Attached`
- B) `ConnectRFSISOImage()`: Invoke the method, successful return value is 0
- C) `GetRFSISOImageConnectionInfo()`: Invoke the method to view connection information and confirm C) was successful

32.7.2 Disconnect and detach ISO Image exposed via RFS USB end point

Following sequence of CIM Operations shall be used to disconnect and detach the ISO Image that is exposed via RFS USB end point to host server.

Applies to: LC2+

Prerequisites for script: none

Script: `DisconnectRFSISOImage.win`

NOTE: Check of Lifecycle Controller (LC) remote service state, via `GetRemoteServicesAPIStatus()`, is not required since ISO is connected using RFS USB endpoint and LC status is not relevant.

- A) `DisconnectRFSISOImage()`: Invoke the method, successful return value is 0
- B) `GetRFSISOImageConnectionInfo()`: Invoke the method to confirm the B) was successful

32.7.3 Get RF ISO Image connection Status

The `GetRFSISOImageConnectionInfo()` method is used to provide the status of the ISO Image connection that has been exposed to the host system.

Applies to: LC2+

Prerequisites for script: none

Script: `GetRFSISOImageConnectionInfo.win`

NOTE: Check of Lifecycle Controller (LC) remote service state, via `GetRemoteServicesAPIStatus()`, is not required since ISO is connected using RFS USB endpoint and LC status is not relevant.

- A) `GetRFSISOImageConnectionInfo()`: Invoke the method, successful return value is 0

32.8 Boot to hard drive (HD)

The BootToHD() method is used to boot the system to the hard drive, even if the hard drive is not first in the boot order.

Applies to: LC1.5.2+

Prerequisites for script: none

Script: BootToHD.win

A) The Lifecycle Controller remote service must be in a “ready” state before executing any other WSMAN commands.

 GetRemoteServicesAPIStatus():

B) GetRFSISOImageConnectionInfo(): Invoke the method, successful return value is 0

33 Appendix

33.1 PYTHON scripts README

33.1.1 Purpose

The goal of `recite.py` is to provide a simple and fast interface for the Dell Lifecycle Controller API. It has an interactive mode that is useful to run one off commands against a server as well as batch mode to allow automating a sequence of operations.

33.1.2 Requirements

Client:

Windows XP or greater with Windows Remote Management (`winrm`)

Linux with Web Services for Management client (`wsmncli`)

Python version 2.4 to 2.6

Server:

Dell 11G servers

iDRAC Enterprise version 1.70 (racks and towers), version 3.21 (blades) or greater

Dell Lifecycle Controller version 1.5 or greater

33.1.3 Command line

```
python recite.py [NAME1=VALUE1 NAME2=VALUE2] ["CMD1" "CMD2" ...] [batch1.win  
batch2.win]
```

Set variable `$NAME1` to `VALUE1`, `$NAME2` to `VALUE2` ...

Execute `CMD1`, `CMD2` in order ...

Execute batch scripts in order and exit ...

Enter interactive mode if no scripts specified

```
python recite.py IP=10.0.0.1,10.0.0.2,10.0.0.3
```

Spawn three instances of `recite.py` in separate windows, each with IP specified

```
python recite.py IP=username:password@10.0.0.1
```

Set \$IP, \$LOGIN and \$PASS with a single assignment

```
python recite.py IP=username:dell123@10.0.0.1,username:dellam@10.0.0.2
```

Spawn two instances with specified \$IP, \$LOGIN and \$PASS

```
python recite.py IP=IP.ini
```

Load IPs from file, one per line, 10.0.0.1 or user:pass@10.0.0.1, # comments a line

```
python recite.py IP=10.0.0.1 GetRSStatus GetLifecycleJobs
```

Execute GetRSStatus and GetLifecycleJobs on specified IP

33.1.4 Commands

Most of the API methods exposed by the Dell Lifecycle Controller WSMAN interface are supported.

The script also provides a list of common internal commands to allow for minimal programmatic functionality. These include:-

<u>Command</u>	<u>Shortcut</u>
----------------	-----------------

Batch	
-------	--

Clear	
-------	--

Context	//
---------	----

Count	+
-------	---

Find	/
------	---

Gosub	>>
-------	----

Goto	>
------	---

If	?
----	---

Log	
-----	--

Print <

Return

Set \$

Sleep

Unset ~\$

Until {

Use the help command in interactive mode to see further details on all available commands and methods and the required syntax.

Apart from the syntax described in help, commands can also be concatenated on methods. This allows for a cleaner syntax.

E.g.

```
CreateRAIDConfigJob Target=$ctlr RebootJobType=3 {ReturnValue=4096 /$jid=InstanceID
```

```
Perform Until loop
```

```
On success, perform Find operation
```

```
GetRSStatus {Status=Reloading {Status=Ready
```

```
Perform Until looking for Status=Reloading
```

```
Perform Until looking for Status=Ready
```

```
GetLifecycleJobs +$njob ?$njob=1 >End
```

```
Count number of jobs
```

```
If only one job, Goto End
```

Script execution is terminated if:

- A command returns an error. E.g. Find, Context, etc.
- A method returns no data. E.g. GetPhysicalDiskViews when no disks are present.
- A command has a syntax error

In order to ignore such errors and resume execution, prepend command with a -.

For example:

-Find InstanceID \$id

-GetPhysicalDiskViews

33.1.5 Settable variables

The following variables are loaded from environment variables if available. If not, they are default initialized as specified.

\$IP

IP of the iDRAC against which WS-MAN commands are to be executed. Default: ""

Set \$IP 10.0.0.1

Set \$IP username:password@10.0.0.1

\$LOGIN

iDRAC username with WS-MAN privileges. Default: username

Set \$LOGIN username

\$PASS

iDRAC password. Default: password

Set \$PASS dell123

\$TIMER

If True, display time taken by WS-MAN command. Default: False

Set \$TIMER True

\$USLEEP

Default sleep delay in seconds used by until commands between method invocations.

Set \$USLEEP 20

\$UTIMEOUT

Default total delay in seconds used by until commands before giving up.

Set \$UTIMEOUT 900

\$VERBOSE

Control level of output from recite.py

Set \$VERBOSE x

where x is:

0: Quiet

1: WS-MAN

2: Full

33.1.6 Internal variables

\$_BATCHFILE

Name of current batch file (including path) with \ and / replaced with _.

\$_DATE

Current date and time in yyyymmddhhmmss format.

\$_LOCALIP

IP of the local system where script is running.

\$_LINE

Current line number in a batch script.

33.2 System check information

33.2.1 Check System Power State

- System power status is available from CMC (racadm/WS-MAN), iDRAC (racadm) and LC.
 - o Enumerate the CIM_ComputerSystem class to get power status from LC as described in section 8.2 of the WSIG for Windows
- If system is not in a state required:
 - o Error to user stating system is not in power state required

33.2.2 Check RS status

- Check that **Status = Ready** as described in section 20 of the WSIG for Windows
- Poll every **30 seconds** until **Status** changes as required
- If target system is not Ready, wait for up to **5 minutes** before giving up or intervening
- On timeout, options are:-
 - o Error to user stating remote services are not ready
 - o Reset the iDRAC as described in section 8.4 of the WSIG for Windows

33.2.3 Check for pending jobs

- Enumerate all jobs as described in section 10.2.3 of the WSIG for Windows and look for any jobs (besides **JID_CLEARALL**) in an incomplete state - i.e. neither **Completed** nor **Reboot Completed** state.
- If any such jobs found:
 - Invoke **JID_CLEARALL** as described in section 10.2.2 of the WSIG for Windows
 - Poll **GetRSStatus** for **Status = Ready** every **30 seconds** as described in section 20 of the WSIG for Windows

33.2.4 Check for pending configuration

- Inventory NIC and BIOS attributes as described in sections 33.3.3 and 33.3.5.
- If any pending configuration found - i.e. **PendingValue** for any attribute is not blank:
 - o Invoke **DeletePendingConfiguration** on the FQDD in question as described in sections 15.6, 16.15 and 17.8 of the WSIG for Windows

33.2.5 Check CSIOR state

- Get CSIOR status as described in section 12.3 of the WSIG for Windows
- If CSIOR = **Disabled**:
 - o Set CSIOR = **Enabled** as described in section 12.1 of the WSIG for Windows
 - o Reboot the host using **RequestStateChange** as described in section 8.4 of the WSIG for Windows for fresh inventory to be collected

33.3 Inventory information

33.3.1 System inventory

- Enumerate **DCIM_SystemView** class to identify server type and total memory

33.3.2 Software inventory

- Enumerate *DCIM_SoftwareIdentity* class for all firmware version levels

33.3.3 BIOS inventory

- Enumerate *DCIM_BIOSEnumeration* class for BIOS attributes of interest

33.3.4 Boot order inventory

- Enumerate *DCIM_BootSourceSetting* for current boot order settings

33.3.5 NIC inventory

- Enumerate *DCIM_NICView* class for total number of NICViews, their types and FQDDs. Note that each NICView represents one port (or partition for a partitioned device). Number of NIC controllers can be calculated by trimming out the second and third octet of the FQDD.
 - o NIC.Mezzanine.2B-1-1 and NIC.Mezzanine.2B-1-2 are two partitions on the same controller: NIC.Mezzanine.2B
 - o NIC.Slot.1-1 and NIC.Slot.1-2 are two ports on the same controller: NIC.Slot.1
- *DCIM_NICEnumeration*, *DCIM_NICString* and *DCIM_NICInteger* classes for all NIC attributes

33.3.6 RAID inventory

- Enumerate *DCIM_ControllerView* class for total number of RAIDs

33.4 Poll LC jobs information

There are various tasks that are executed in sequence when running one or more LC jobs. Once the job is scheduled using *ScheduledStartTime*, note that the machine only reboots if a *RebootJobType* is specified in the *CreateTargetedConfigJob* method invocation or a reboot job is created using *CreateRebootJob* and scheduled using *SetupJobQueue*.

33.4.1 Timing considerations

- While polling jobs for completion, the following target machine specific variables need to be considered when setting reasonable timeouts for job completion:

Amount of RAM in machine

- o Influences time taken for initial memory check
- o Details obtained from enumeration described in section 5.3

Number of NIC and RAID devices

- o Influences time taken for:
 - POST - controller initialization
 - UEFI initialization - controller driver load and start for CSIOR and SSM
 - Inventory - for CSIOR and SSM
- o Details obtained from enumerations described in sections 33.3.3 and 33.3.5

33.4.2 Machine reboot

- If the machine is turned off, it is turned on in order to execute the jobs.
- If a machine is turned on, it is powercycled at the *ScheduledStartTime* depending on the *RebootJobType* specified.
- Once all jobs are successfully scheduled, the target machine power state can be polled as

described in section 5.2.1

- The total time taken for reboot depends on the *RebootJobType* specified.
 - o For a machine powered down, it shouldn't take more than **30 seconds** to power up.
 - o For a running machine, timeout depends on the *RebootJobType*:
 - 1 = PowerCycle - **30 seconds**
 - 2 = Graceful Reboot without forced shutdown - **5 minutes**
 - 3 = Graceful reboot with forced shutdown - **5 minutes**

33.4.3 POST

33.4.3.1 Memory check

- Get the value of the BIOSEnumeration attribute *MemTest*, obtained during inventory as described in section 5.3.3.
- If *MemTest* = *Enabled*, on power on, the BIOS memory test is executed.
- If memory test is executed, the total timeout for POST should include **10 seconds per GB of RAM** to check the total RAM installed on the target system, as obtained from enumeration described in section 33.3.

33.4.3.2 Controller initialization

- Get the total number of NIC and RAID controllers on the target system, obtained from enumerations described in sections 33.3.5 and 33.3.6.
- The total timeout for POST should include **10 seconds** to initialize each NIC controller installed on the target system.
- The total timeout for POST should include **1 minute** to initialize each RAID controller installed on the target system.

33.4.4 SSM

33.4.4.1 UEFI initialization

- Before executing SSM, the UEFI environment needs to load into memory. This includes various BIOS, NIC, RAID and LC drivers that are loaded and started. This also includes initialization time for various NIC device drivers which populate the HII database with their attribute configuration for consumption by LC.
- The total timeout for SSM should include **2 minutes** to load all BIOS and LC components.
- The total timeout for SSM should include **30 seconds** to load and initialize each NIC driver installed on the target system.

33.4.4.2 Job execution

- Once SSM starts to execute a job, *JobStatus* will transition from *Scheduled* to *Running* to *Completed*, *Completed with Errors*, or *Failed*.
- The total timeout for SSM should include **5-10 minutes** per job executed depending on the type of job.
- Error to user if *JobStatus* != *Completed* or timeout occurs.
- If *JobStatus* = *Completed with Errors*, attributes that failed to set can be obtained from the LCL as described in section 12.13 of the WSIG for Windows.
- Completion of all jobs from the *JobStatus* perspective will suggest that all job execution tasks are done. However, various LC tasks such as inventory and refresh will still be in progress. The timeouts for these tasks can be accounted for in the next section.
- *JobStatus* can be obtained as described in section 10.2.3 of the WSIG for Windows.

33.4.4.3 Inventory

- After all jobs are executed, SSM will re-inventory the system and signal the iDRAC to re-sync its database.
- The total timeout for SSM should include **1 minute** to inventory each NIC FQDD on the target system after job completion.
- The total timeout for SSM should include **30 seconds** to inventory each RAID controller installed on the target system after job completion.

33.4.4.4 Cleanup

- The total timeout for SSM should include **2 minutes** to unload and cleanup the UEFI environment prior to reboot.

33.4.5 RSStatus/JobStatus

- After SSM completes, the system will reboot and proceed with CSIOR, as described in 33.4.7.
- In parallel, the iDRAC will refresh its database based on updated inventory.
- The total timeout for *RSStatus* / *JobStatus* should include **5 minutes** to obtain the inventory data generated and update the iDRAC database.
- Check *Status* = *Reloading* and then *Status* = *Ready* as described in section 20 of the WSIG for Windows.

33.4.6 Check refreshed data

- Once *RSStatus* / *JobStatus* are *Ready* / *Completed* respectively, NIC and BIOS need to be re-inventoried to ensure that all pending data was cleared and the set values were successfully applied.
- NIC and BIOS inventory are described in sections 33.3.3 and 33.3.5.
- Error to user stating failures if any pending values still persist or if set values weren't applied as required.

33.4.7 CSIOR

- On the server side, the following tasks are redone since the machine will reboot and perform CSIOR.
- The overall timeout for SSM should include the following timeouts:
 - o POST - as described in section 33.4.3
 - o CSIOR - UEFI Initialization, similar to section 33.4.1
 - o CSIOR - Inventory
 - o CSIOR - Cleanup

33.5 iSCSI boot information

In addition to the programmatic steps shown in section 4.16, additional detailed information about the script is added below.

1. Check FQDD if LOM/NDC or add-in
 - o On 11G
 - Embedded = LOM
 - Integrated = LOM
 - o On 12G
 - Embedded = LOM
 - Integrated = NDC
 - o Addins can be Slot, Mezzanine, etc.
2. Check LOM/NDC enablement

- For LOM
 - EmbNic1Nic2 needs to be enabled for 1-1, 2-1
 - EmbNic3Nic4 needs to be enabled for 3-1, 4-1
 - And so forth
 - For NDC
 - IntegratedNetwork1 needs to be enabled for 1-1, 1-2
 - IntegratedNetwork2 needs to be enabled for 2-1, 2-2
 - And so forth
 - Addins
 - Cannot be disabled on 11G
 - On 12G, individual slots can be disabled, TBD if this needs to be addressed
 - Create a BIOS job
 - EmbNic1Nic2 = Enabled or IntegratedNetwork1 = Enabled
 - BootMode = Bios
 - For Broadcom NICs
 - Disable all IPL boot sources
 - Since target NIC is disabled, it isn't in the boot list
 - We are doing a BIOS job anyway, so might as well remove other boot sources
 - Wait for job completion
 - Wait for CSIOR to complete
 - Since boot source changes only occur after reboot, they get detected only after CSIOR and refresh
3. Check if FQDD is present in NICView enumeration
- If NIC is still not present, it is an invalid NIC FQDD, exit
4. Look for NIC in boot sources
- For Broadcom NICs
 - Look for IPL and NIC FQDD in InstanceIDs in boot source enumeration
 - If FQDD not in boot sources
 - Create a BIOS job
 - BootMode = Bios if not already done
 - Disable all IPL boot sources if not already done
 - Since target NIC isn't in boot list yet, we can remove other boot sources
 - Create a NIC job
 - LegacyBootProto = iSCSI
 - Adds Broadcom device into boot list in iSCSI boot mode
 - Set all iSCSI boot configuration attributes
 - Wait for both jobs to complete
 - Wait for CSIOR to complete
 - Since boot source changes only occur after reboot, they get detected only after CSIOR and refresh
5. Check if NIC is primary bootable device in boot order
- For Broadcom NICs
 - Verify if NIC will boot first
 - Get EnabledState of IPL entry for NIC FQDD in boot sources
 - Needs to be enabled, if not, need to do a BIOS job
 - Get assigned sequence number
 - If not first, need to ensure all preceding sources are disabled
 - If other sources will boot before NIC FQDD, need to do a BIOS job
 - If not enabled or a secondary device in boot order
 - Create a BIOS job
 - Set EnabledState for IPL entry of NIC FQDD to 1
 - Set assigned sequence to 0 so that it boots first

- Create a NIC job
 - Set all iSCSI boot configuration attributes
 - Wait for both jobs to complete
 - Wait for CSIOR to complete
 - Since boot source changes only occur after reboot, they get detected only after CSIOR and refresh
6. iSCSI configuration settings
- For Broadcom
 - IscsiViaDHCP = Disabled
 - TcpViaDHCP = Disabled
 - ConnectFirstTgt = Enabled
 - IscsiInitiatorIpAddr = <IP of initiator>
 - IscsiInitiatorSubnet = <Subnet mask for initiator>
 - IscsiInitiatorGateway = <Gateway for initiator>
 - IscsiInitiatorName = <Initiator name>
 - IscsiTgtBoot = Enabled
 - FirstHddTarget = Disabled
 - FirstTgtIpAddress = <IP of target>
 - FirstTgtIscsiName = <Target name>
 - FirstTgtBootLun = <Target LUN>
7. System should boot into iSCSI as needed